

-90 -80 -70 -60 -50 -40 -30 -20 -10

-10

-20

Flow Rate Meter DMZ-8E





Index

1	General remarks.....	3
2	Function	3
2.1	Dosage control.....	3
2.1.1	Monitoring of dosing time	3
2.1.2	Release inputs	3
2.1.3	Handling on front keys and manual dosage	4
2.2	Flow monitor	4
3	Display	4
3.1	Flow quantity / rate of flow (Q/Q-point)	4
3.2	Limit values and elapsed dosing time.....	4
3.3	The LED 'Gebersignal' (transmitter signal)	4
3.4	Transmitter factor.....	5
4	Current output	5
5	Behaviour on mains power return	5
6	Fault message relay	5
7	Entry of pre-selection values and parameters	6
7.1	General.....	6
7.2	Selection of parameters.....	6
7.3	Entry mode	6
7.3.1	Parameters with changeable decimal point.....	6
7.4	List of parameters	7
8	Connection diagram	8
9	Technical Data	8
9.1	Ordering information.....	9
10	Notes for installation	9
11	Connection example.....	10





1 General remarks

The flow rate meter DMZ-8E serves for dosage or filling of a pre-selectable liquid quantity using two adjustable limit values. Moreover the unit counts the flow rate and may thus be used as parameterisable flow monitor. A free configurable current output can be allocated either to the quantity or the speed. Signal transmitters are commercially available flow rate transmitters, which generate quantity proportional impulses. This may be for example water meters with contact or impeller wheel sensor. By its manifold configuration and parameterisation possibilities the device can be perfectly adapted to the desired application purpose.

2 Function

2.1 Dosage control

As soon as a dosage demand has reached one of the external release entries, the dosing procedure is started. The quantity counter is set back automatically and the relays K1, K2 and K3 pick up. LED 'Dosierung' (dosage) lights up. When limit value 1 is reached relay K1 releases, LED 'Grenzwert 1' (limit value1) lights up and the dosage is completed. The behaviour of relay K3 is dependant on parameter '0.1'. The possible selection is among creeping contact, limit contact and sequential contact. Relay K2 is firmly adjusted as creeping contact. The relay releases when the flow rate's (limit value 1, par. 1.1.) percentage (par. 1.5) is reached.

2.1.1 Monitoring of dosing time

A timer is started with each dosage procedure that measures the time of the dosage in process. At the start of a dosage the timer is set to zero. In case of an temporary halt or a stop this timer also will be halted. Thus always the running time of a dosage procedure or the duration of the finished dosage respectively can be called up. If for max. dosage time a value larger zero is entered, the monitoring of dosing time is activated. In case the dosing procedure takes longer than the max. dosage time, the dosage will be finished independently from the recorded quantity. The LED 'T max' lights up, the display shows the elapsed dosing time in seconds. At the same time the fault message relay K7 releases, what can be utilised as alarm message.

2.1.2 Release inputs

The device is equipped with 2 release inputs:

- neutral make contact at terminal 39 (E1) to GND (terminal 43), undelayed.
- neutral make contact at terminal 40 (E2) to GND (terminal 43), 1 second delayed ex works (serves the identification of the stable status of release).

The release behaviour depends on DIL-S4:

- DIL-Switch S4 'ON' : The dosage will be executed after release (pulse, rising edge) until reaching limit value 1 (parameter 1.1) irrespective of the other inputs.
- DIL-Switch S4 'OFF': The dosage will be executed as long as the release is present. If it ends before the limit value 1 (parameter 1.1) is achieved, the dosage also will be halted.

The LED 'Freigabe' (release) indicates a current release.

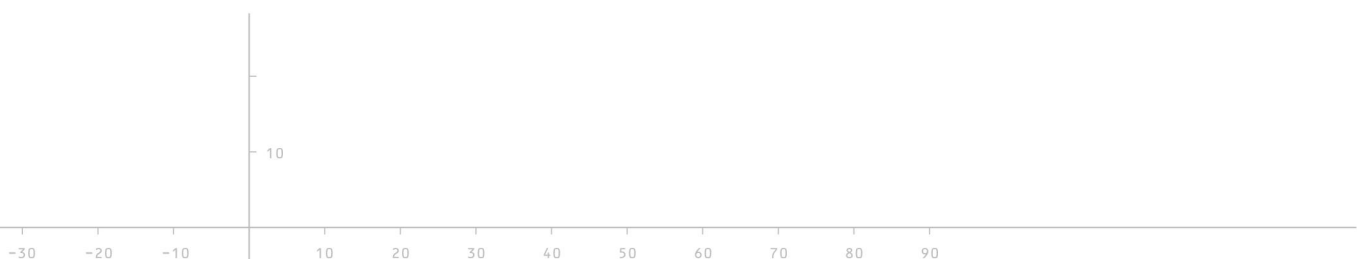



2.1.3 Handling on front keys and manual dosage

Using the front keys a current dosage can be interrupted, continued or stopped at all times:

An ongoing dosage is interrupted by pressing the 'Enter' – key.

The relays K1, K2, K3 and K5 will release and the LEDs 'Dosierung' and 'T max' flash alternately. The dosage will be continued with the 'Weiter' (next) – key (press for longer than 1 second) or will be halted by pressing 'Enter' (for longer than 1 second) once more. The relays K1, K2, K3 and K5 will release, LED 'Bereit' (ready) lights up. In case of an existing release, dosage will be started by pressing the 'Enter' – key. Dosage can be carried out manually. The sequence of functions than is always:

Step	'Weiter' – key	'Enter' – key
1		start / dosing
2		pause
3	resume dosage	stop

After an interrupting, it's possible to switch back and forth between resume and pause by using the 'Weiter' (next) – and the 'Enter' – key.

2.2 Flow monitor

In addition to the flow quantity the unit reads at the same time also the rate of flow. The relay K5 works as limit contact for the rate of flow, whereby pick up – and release – value can be parameterised independently from each other.

3 Display

3.1 Flow quantity / rate of flow (Q/Q-point)

The device can display the passed quantity as well as the actual rate of flow. Switching between display modes is done by pressing 'weiter' (next), whilst leaving it pressed for longer than 1 second. The selected mode is indicated by the unit – LEDs (l & l/h) above the display. The selected display mode does not influence function of the device.



Note: For service purposes, the pulse frequency of the sensor displayed, if in 'Durchflussgeschwindigkeit' (flow rate) – mode Dil-S2 is set 'ON'. In this case, none of the unit – LEDs lights up.

3.2 Limit values and elapsed dosing time

In operation modes 'Dosierung' (dosage) and 'Bereit' (ready) both limit values for the quantity and the running or the elapsed dosing time can be displayed by pressing the 'Weiter' (next) – key.

- The first keystroke shows limit value 1, the associated LED flashes.
- The second keystroke shows limit value 2, the associated LED flashes.
- The second keystroke shows the dosing time, the LED 'T max' flashes.
- After another keystroke on 'Weiter' (next) or after 10 seconds the flow quantity respectively the flow rate is displayed again.

3.3 The LED 'Gebersignal' (transmitter signal)

This LED indicates the impulse level of the flow sensor, which is connected on impulse input. In case of pulse frequencies faster than 3Hz the flash frequency of LED will no longer be increased, so that the blinking of the LED properly can be observed. For high transmitter frequencies a pulse scaler (LED-devider) can be parameterised.

10





3.4 Transmitter factor

The transmitter factor is specified in pulses per volume unit. Typically litres or cubic meters are used as volume unit. The device internally calculates with pulses per unit volume also, irrespective of the used unit. But of course the unit used by transmitter should accord to the unit shown on front panel. If necessary the transmitter's unit is to be converted:

1 pulse per litre is equivalent to 1000 pulses per m³.

4 Current output

The current output can be assigned either to the flow quantity or to the current flow rate. Assignment will be done by DIL-Switch S3:

- DIL-Switch S3 'ON' : current output follows the rate of flow.
- DIL-Switch S3 'OFF': current output follows the passed flow quantity.

The current output can be parameterised for 0 ... 20mA and for 4...20mA. Output current then never is lower than 0 (4) mA and never higher than 20 mA. Initial value and final value can be parameterised. If the initial value is larger than the final value, the current exit works inverse, i.e. a rising initial value entails the decrease of the output current.

5 Behaviour on mains power return

In case of mains power failure, the values for operating status, counter and elapsed dosing time remain intact. The release inputs behave on power return as followed:

For the undelayed Input 1 applies:

- A dosage started by this input will be continued, if immediately after the power return a release already, respectively still exists. release interruptions during the power failure have no consequences.
- A release emerging during a power failure don't starts a dosage!
Therefor: to start a new dosage, a rising edge is always needed!

For the delayed (debounced) input 2 applies:

- A dosage started by this input will be continued after a power failure, only if within the pre-adjusted delay time (parameter 8.5) after power return a release either occurs or still exists.
- A release activated during mains power failure, starts a new dosage after the power failure, only if this release after elapse of the pre-adjusted delay time parameter 8.5) still exists. This option is created to observe eventually existing delay times of connected switching devices or control units after power failure.
- If the DIL-Switch S4 is set 'ON' (release enabled via pulse), a dosage, started before power failure always will be continued after power return, irrespectively of the release inputs.

6 Fault message relay

The relay K7 (terminals 20, 21) serves as output for fault messages. Normally this relay is picked up (closed-circuit principle). In case of power failure or excess of the maximum dosing time (chap.2.1.1), the relay K7 releases (closed-circuit principle).

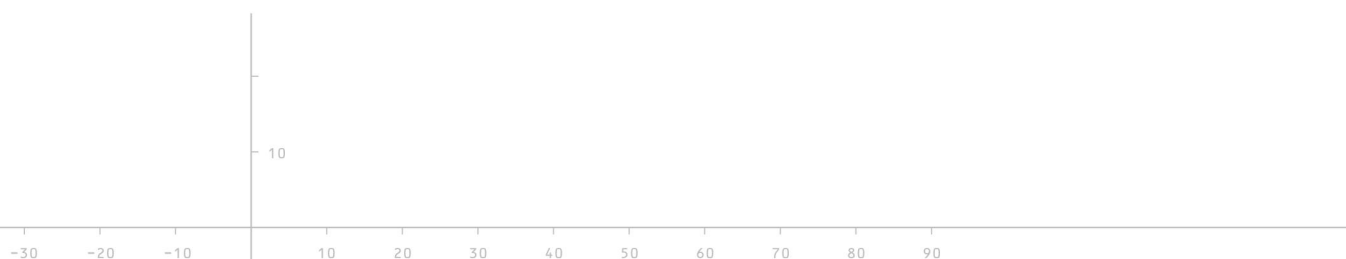



7 Entry of pre-selection values and parameters

7.1 General

By simultaneous pressing of the keys 'Weiter' (next) and 'Enter' the device switches into the parameter selection mode. Relays K1, K2, K3 and K5 are switched off.

If DIL-Switch S1 is in 'OFF' position, only parameters 1.1 to 1.4 / 1.5 can be altered. If DIL-Switch S1 is in 'ON' position, all parameters from parameter 0.1 to 5.3 can be reached. If additionally DIL-Switch S2 is in 'ON' position, also parameters 8.1 to 8.5 can be adjusted.

The return into operating-mode is done either by simultaneously pressing 'Weiter' – and 'Enter' – key, or automatically when 60 seconds elapsed without actuating any key.

7.2 Selection of parameters

In the parameterisation mode the two middle digits of the display indicate the number of the current parameter. The parameters are collected to groups on several levels:

- The digit of parameter number left-hand of the dot denotes the parameter level.
- On short-time actuating the 'Weiter' (next) – key number of parameter *right-hand of the dot* will be increased on releasing the key.
- Longer actuating the 'Weiter' – key (more than 1 second) the number of parameter level *left-hand of the dot* will be increased.
- By pressing 'Enter' the value of the selected parameter is shown. The device is now in entry mode (chap 7.3). A further actuating of 'Enter' switches the device back into the parameter selection mode.

7.3 Entry mode

When entering the entry mode the parameter to be altered is displayed. Pressing 'Enter' again the entry mode will be quitted directly – without changing the parameter. Actuating 'Weiter' the altering of parameter is started:

- the first 3 digits darken, the 4th is counted up with the 'Weiter' (next) – key;
- pressing 'Enter' the value will be set and the 3rd digit can be altered.

The highlighted digit is increased by actuating the 'Weiter' – key (after 9 follows 0). Pressing 'Enter' will take over the set value and jump to the following digit.

When all 4 digits are taken over:

- all digits are lighted with the same brightness;
- press 'Enter' to turn back to the parameter selection;
- press 'Weiter' (next) to repeat this entry.

7.3.1 Parameters with changeable decimal point

Changing the position of the decimal point is done in parameter 5.5. Therefor all digits have to be taken over.

When all 4 digits are taken over:

- all digits are lighted with the same brightness;
- the decimal point flashes at the chosen position;
- press 'Weiter' (next) to change the decimal points position;
- a new position will be taken over with 'Enter'.

When all 4 digits and the decimal point are taken over:

- the decimal point lights continously;
- with 'Enter' back to the parameter selection
- actuate 'Weiter' (next) to repeat the input

10



7.4 List of parameters

Page 1 of 1

Comm.: _____

Date: _____

Level	Ident-No	Parameter	Description	Range	Preset ex works	set
0	1	System parameters	Device – parameters for Relay output K3	0000 ... 0050	0000	
		 <p><i>Note: For System parameter 0.1 there is - how to see at right-hand – only the second digit to change.</i></p>	switched off : 0000 creeping quantity (xx% of Par. 1.1) : 0010 limit contact (limit value 2, Par. 1.2) : 0020 limit contact with release : 0030 sequential contact : 0040 sequential contact with release : 0050			
1	1	limit value 1 Quantity		00.00 ... 9999 [l]	005.0	
	2	limit value 2 Quantity	position of decimal point as in parameter 1.1	00.00 ... 9999 [l]	010.0	
	3	limit value rate of flow on		00.00 ... 9999 [l/h]	100.0	
	4	limit value rate of flow off	position of decimal point as in parameter 1.3	00.00 ... 9999 [l/h]	050.0	
	5	series contact	percentage of limit value 1	00.00 ... 99.99 [%]	0000	
2	1	transmitter factor		0000 ... 9999 [Imp/l]	1000	
	2	limit frequency		10 / 20 / 50 / 100 / 200 / 300 / 500 [Hz]	0200	
4	1	max. dosing time		0000 ... 9999 [s]	0000	
5	1	current output 0 ... 20 / 4 ... 20 mA		0.020 / 0.420	0.020	
	2	initial value current outlet		00.00 ... 9999 [l] or [l/h]	000.0	
	3	final value current outlet		00.00 ... 9999 [l] or [l/h]	200.0	
8	1	max. waiting time for recognition of no flow		00.00 ... 9999 [s]	003.0	
	2	integration time for Q – Point		00.00 ... 9999 [s]	002.0	
	3	LED-divider / Relay - divider		1 / 2 / 4 / 8 / 16 / 32 / 64 / 128	0016	
	4	debouncing of signal		1 ... 20 / 30 / 40 / ... / 250 [program – cycles ~ ms]	0018	
	5	debouncing release input		0000 ... 9999 [program – cycles ~ ms]	0500	





8 Connection diagram

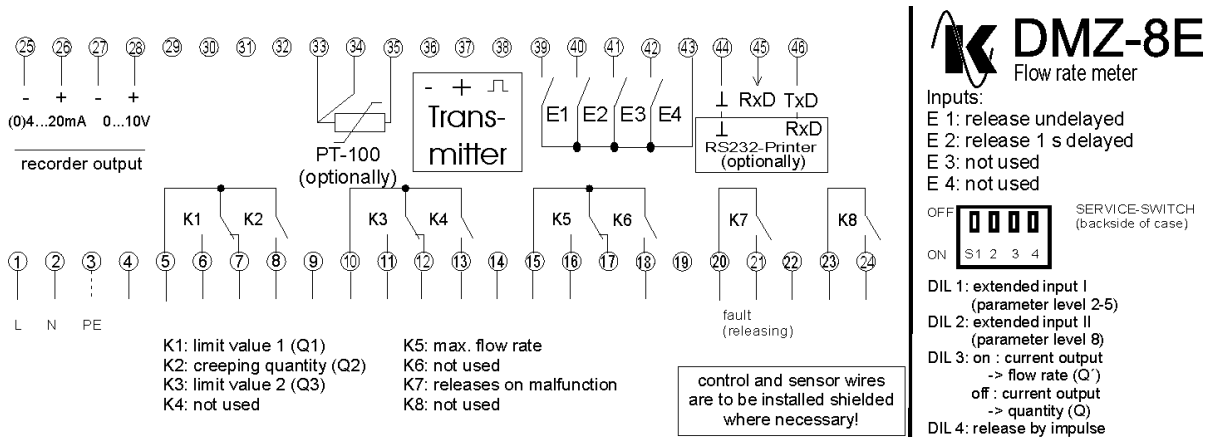

9 Technical Data

Operating voltage	230 V AC +5%/-10%, 50 Hz
Power consumption	approx. 12 VA
Fuse	4 A mT
Inputs	4 x neutral make contact to GND contact potential approx. 10 V DC, I approx. 9 mA transition resistance max. 1,5 kOhm
Relay outputs	5 x neutral, max. 230 V AC, 2A
Current output	0(4)...20 mA max. load 400 Ohm linearity: 0.5% FS
Voltage output	0-10V (+/-0,5 %) linearity: 0.5 % FS
Transmitter	water meter with neutral contact or NPN open collector or impeller sensor with NPN open collector
Transmitter supply	10 V, 30 mA current limited
Transmitter factor	0.01 ... 9999 impulses/litre
max. transmitter frequency	500 Hz (adjustable); programmable contact debouncing by maximum transmitter frequency
Ambient temperature	-22 ... +55 °C
Housing	switch board housing according to DIN 43700 (IP40) optional with transparent lid IP54 in front of switchboard Dimensions W / H / D : 144 x 72 x 116,6 mm; with transparent lid D: 144 mm
Cut-out dimensions	W / H 137 x 67 mm

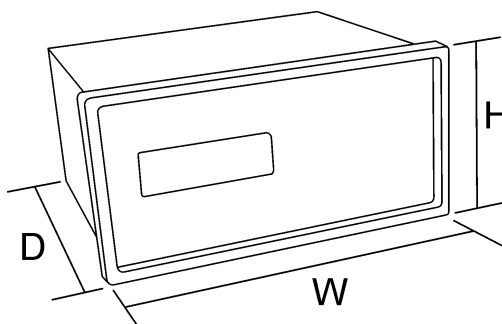

10

-30 -20 -10

10 20 30 40 50 60 70 80 90



9.1 Ordering information

Flow rate meter DMZ-4.2W

Part number

E1726

10 Notes for installation



For the selection of lines and for the electrical connection of the unit the regulations of VDE 0100 'Directives for the Installation of Power Installations with Nominal Voltages below 1000 V' and the respective local stipulations. The electrical connection must only be effected by trained experts.

For maintenance and installation work the device is to disconnect from the mains.

The external fuse protection of the unit's power supply should not exceed a value of 4 A mT. In order to avoid a welding of the exit relay contacts in case of short-circuit, take strictly care that the load circuit is protected at maximum relay current (2A).

Electrical and magnetic fields in the unit's surroundings may prejudice the function. Anti-interference measures such as RC combinations, must be taken for inductive consumers that may be installed in the devices vicinity.

In extreme cases the device must be operated through an isolating transformer, for ex. when strong mains fluctuations outside the indicated tolerances are to be expected.





11 Connection example

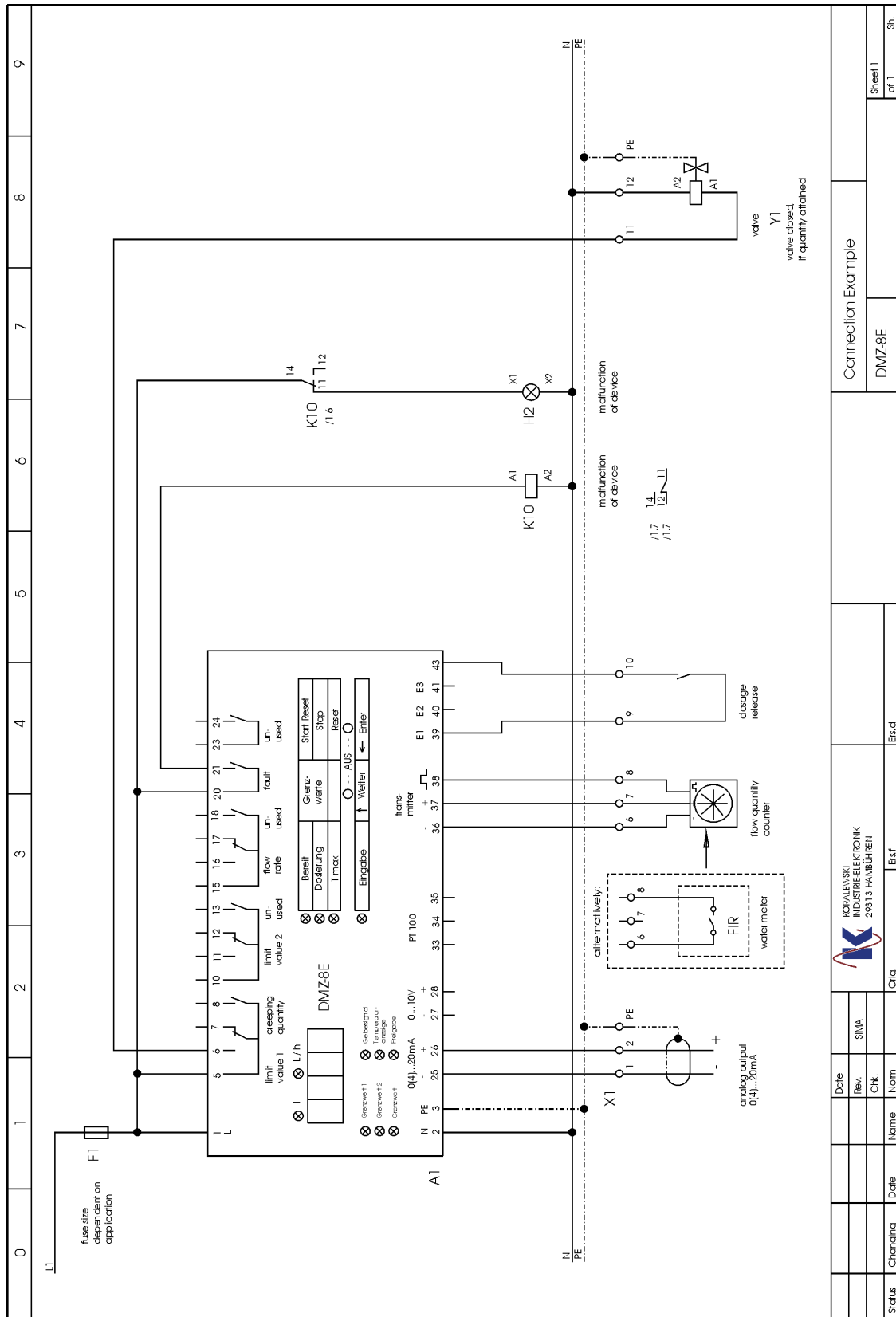

Date		SMA	
Rev.		CHK.	
Name		Norm	
Changing	Date	Orig.	Escd
KORALEWSKI INDUSTRIELEKTRONIK 29613 HAMBURGEN		Escd	
Connection Example		DMZ-8E	
Sheet 1		Sh.	