

-90 -80 -70 -60 -50 -40 -30 -20 -10

-10

-20

# Filter Control FS-201





Index

1	General Information.....	4
1.1	Equipment .....	4
2	Installation.....	5
2.1	Mechanical Installation .....	5
2.2	Electrical Installation.....	5
2.2.1	Connection Diagram.....	6
3	Operation .....	6
3.1	Overview of the Display and Operating Elements.....	6
3.1.1	The LED – Indicators .....	7
3.2	The 7-Segment Display View (only FS-201).....	7
3.3	The LCD Display.....	8
3.3.1	One Filter Operating Mode.....	8
3.3.2	Two Filter Operating Mode.....	8
3.3.3	Parameter Mode.....	8
3.4	Function of the Keys.....	9
3.4.1	Key Combinations.....	9
3.5	Operating Concept.....	10
3.5.1	Editing Parameters .....	11
4	Starting Up .....	11
4.1	Unit Configuration (Filter Configuration) .....	11
4.1.1	One Filter Mode .....	11
4.1.2	Two Filter Mode .....	11
4.1.3	Two Filter Mode with Half – Duplex Transmission .....	12
4.1.4	Cancel First Filtrate .....	12
4.1.5	Two Filter Mode in Parallel Operation .....	12
4.2	Regeneration Release.....	12
4.2.1	Regeneration Release according to Time .....	12
4.2.2	Setting the Regeneration Release Time.....	13
4.2.3	Regeneration Release according to Quality .....	13
4.2.4	Regeneration Release according to Quality (delayed) .....	13
4.2.5	Regeneration Release according to Quantity.....	13
4.2.6	Regeneration Release according to Quantity (delayed) .....	13
4.2.7	Regeneration Release according to Minimum Quantity.....	14
4.2.8	Regeneration Release according to Minimum Quantity (delayed) .....	14
4.2.9	Regeneration Release according to Maximum Quantity.....	14
4.2.10	Regeneration Release according to Maximum Quantity (delayed) .....	14
4.2.11	Setting the Regeneration Quantities .....	15
4.3	Valve Selection .....	16
4.3.1	User defined Valve .....	16
4.4	Impulse Duration.....	16
4.5	Step Timings.....	16
5	System and Indicators .....	17
5.1	Changing Languages .....	17
5.2	View Change Time.....	17
5.3	View Reset Time.....	17
5.4	Standard View .....	17
5.5	The 7 – Segment Display View.....	18
6	Service.....	18
6.1	Service Messages.....	18
6.2	Regenerant Monitoring.....	19
6.3	Service Reset .....	19

10



Index

---

7	Operating Value Settings .....	19
7.1	Regeneration Counter .....	19
8	Inputs .....	20
9	Outputs .....	21
10	Setting the Time .....	23
11	Manual Operating Options .....	24
11.1	Changing the Filter in Automatic Mode.....	24
11.2	Hand Operation.....	24
11.3	Regeneration Release in Hand Operation .....	24
11.4	Skip to Next Regeneration Step in Hand Operation .....	24
12	Fault Messages .....	24
13	Application and Configuration Examples .....	25
13.1	Operation when Interconnected via a Data Bus (in Preparation).....	25
13.2	Connection of Two FS-201 in Interconnected Operation .....	25
13.3	Connection of Several FS-201s in Interconnected Operation .....	25
13.4	Capacity Setting in Parallel Operation .....	26
14	Technical Data .....	27
14.1	Ordering Information .....	27
15	Connection Examples.....	28
16	Default Settings .....	30
17	Form for Configuration and Parameter Settings .....	31





# 1 General Information

The FS-201 filter control unit serves to control a one- or two-filter system equipped with pilot distributors or central control valves. The valve types are selected by means of the parameter settings and the FS-201 automatically adapts to the filters selected as the function progresses. Both decarbonisation filters as well as gravel filters can be controlled.



## 1.1 Equipment

- Large 7 - segment display view for displaying operating values
- 4-line text display for displaying operating states
- Permanent storage of the parameters and operating data in the internal flash memory
- The time is stored in the buffer for at least 72 hours in the event of a power failure
- Operation of several FS-201s is possible together with the option of mutual locking
- 8 relay outputs, 4 of which whose function can be assigned with any regeneration step or event
- Input for monitoring the recycle liquid supply
- Regeneration counter for monitoring the regeneration cycles completed
- Language selection for the text messages (English or German, others on request)
- Interface for connection to a PC. The program supplied enables all configuration data to be setup simply
- Optional, additional card for conductance
- Optional communication interface (RS 485), e.g. for data exchange with a control center

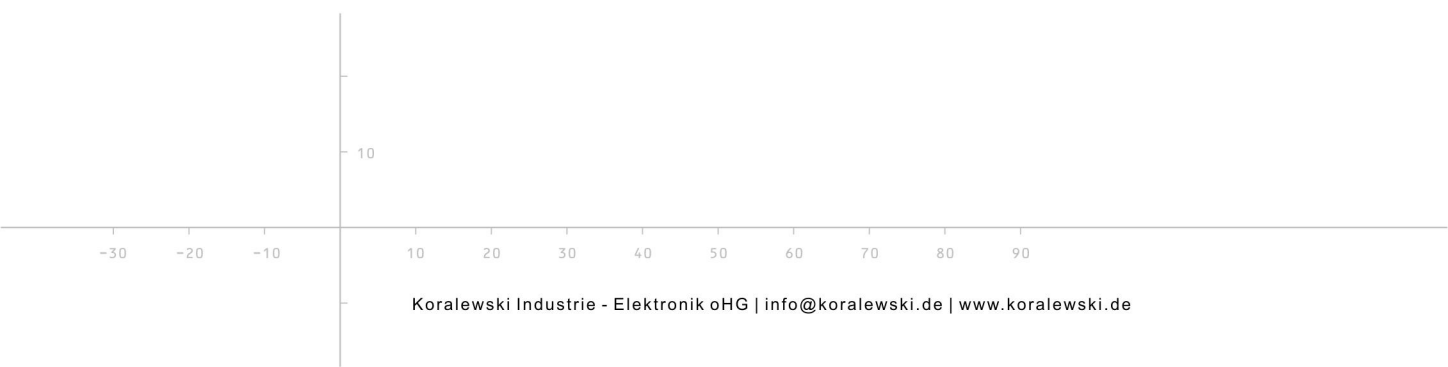

## 2 Installation

### 2.1 Mechanical Installation

Mounting dimensions

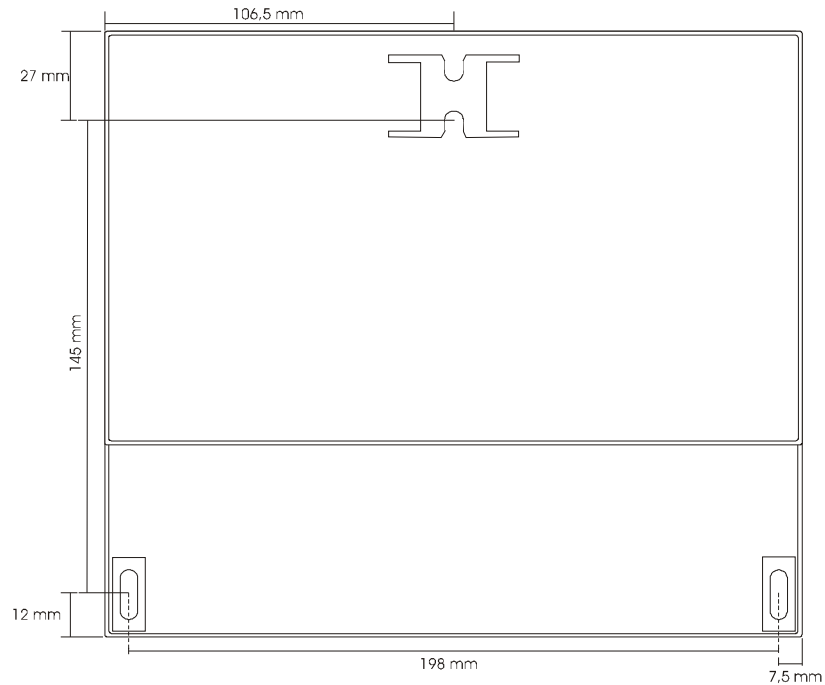

2

### 2.2 Electrical Installation



**Only trained personnel are authorized to assemble and start up the equipment.**

**When selecting the cables and electrical connections for the equipment, observe the directives stipulated in VDE 0100 'Directive defining low-voltage equipment with a nominal voltage under 1000 V', VDE 0160 'Equipping low-voltage equipment with electronic operating resources' and the equivalent, respective country regulations.**

**The electrical connection may only be completed by properly trained personnel (VDE 1000 T. 10).**

**The device must be disconnected from the mains power supply in the event of service and installation work.**





### 2.2.1 Connection Diagram

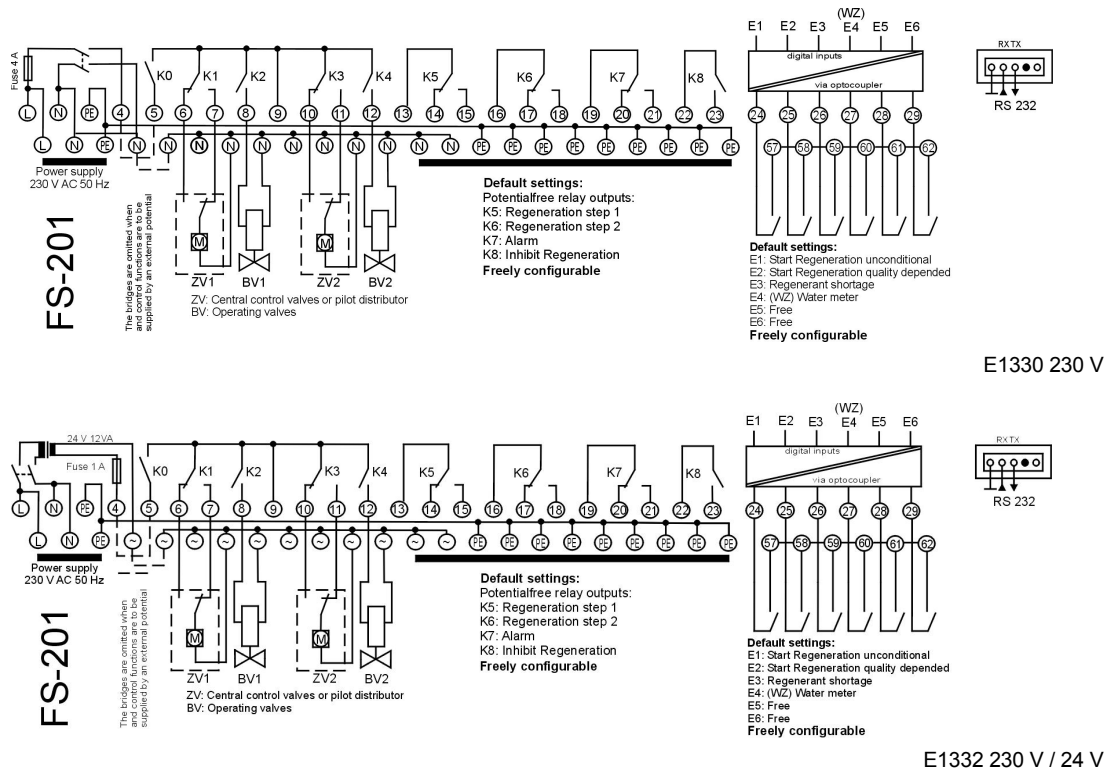

2  
3

## 3 Operation

### 3.1 Overview of the Display and Operating Elements

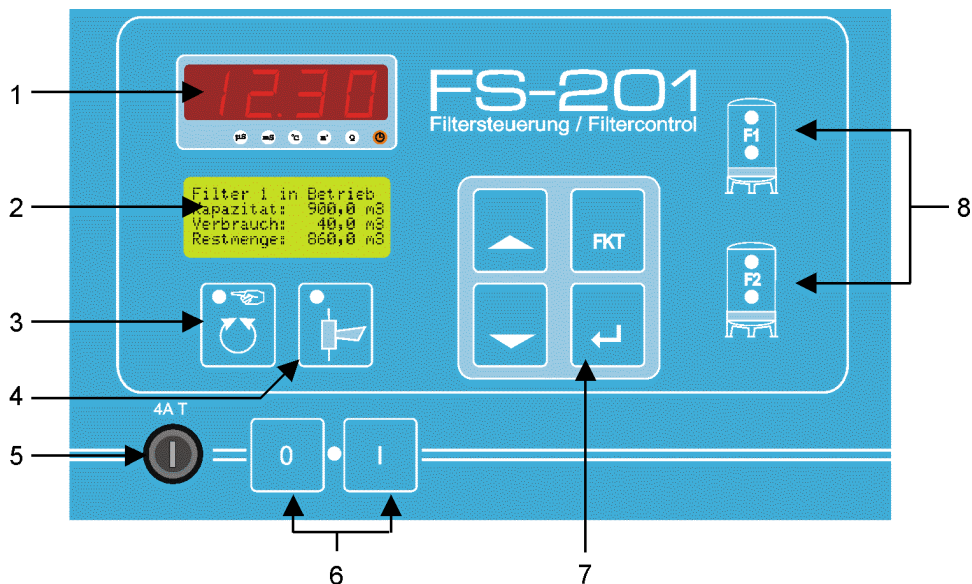

- 1 7-segment - display view
- 2 LCD display
- 3 Hand / Auto - mode key
- 4 Acknowledgement - key
- 5 Device fuse
- 6 On / Off switch
- 7 Operating panel
- 8 Filter status indicators

10

### 3.1.1 The LED – Indicators



LED (green)

Lights up when the device is switched on and power is supplied.

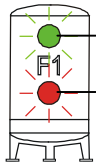

LED 1

LED 1 (green)

Lights up continuously when the filter is in operation. Flashes at 2 s intervals when the filter is ready in standby. Flashes briefly at 1 s intervals during regeneration when the system skips to the next step. Is off when the filter is switched off.

LED 2

LED 2 (yellow)

Lights up continuously when the filter is regenerating.



LED (yellow)

Lights up continuously when the filter is in HAND mode. Is off when the filter control is in AUTO mode.



LED (red)

Flashes at 1 s intervals when a fault has occurred. Lights up continuously when a fault is acknowledged but the cause not yet located.

### 3.2 The 7-Segment Display View (only FS-201)

The icons with back-lighting underneath the display view indicate the respective measuring range or the display mode:

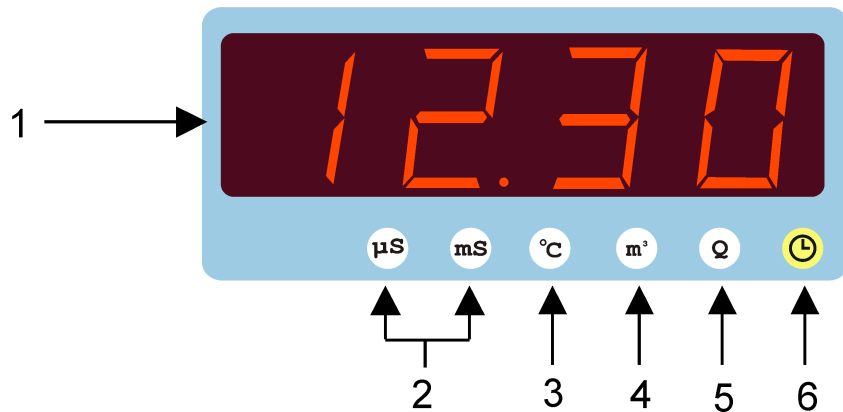

- 1 Displays the current value
- 2 Unit when displaying the value (only possible when the conductance measurement option is available)
- 3 An Indicates the temperature, in °C, associated with the conductance measurement
- 4 Indicates the remaining flow quantity in m<sup>3</sup> up to the next regeneration
- 5 Indicates the water consumption since the last regeneration
- 6 Indicates the time or remaining time until the next time-controlled regeneration is triggered

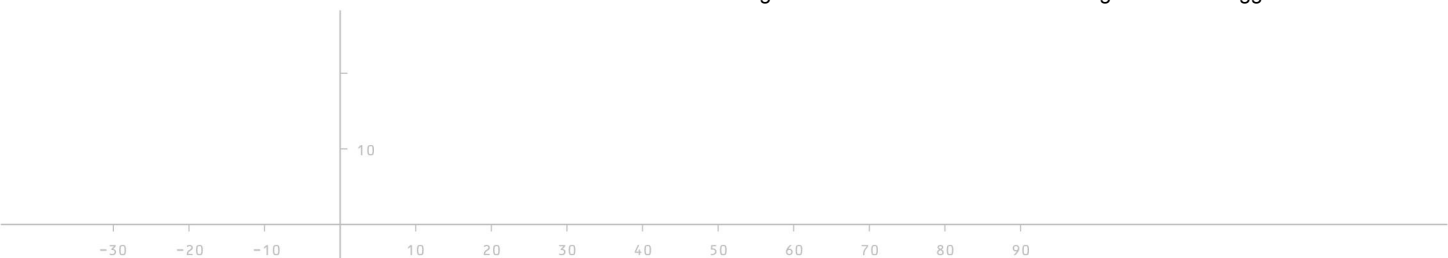



### 3.3 The LCD Display

---

The LCD display serves to display operating states (operating mode) and the parameters (configuration mode).

#### 3.3.1 One Filter Operating Mode

```
Filter 1 operating
Capacity:      10.0 m3
Consumption:  8.0 m3
remaining:    2.0 m3
```

3

#### 3.3.2 Two Filter Operating Mode

More display variations are can be set up in two-filter mode and are explained in more detail in Chapter 4.

```
Filter1 Cap.: 10.0 m3
Consump.:    8.3 m3
Filter2 Cap.: 10.0 m3
Consump.:    5.4 m3
```

*E.g.:* Display of the operating status in two-filter mode. Lines 1 and 2 display the states for Filter 1, Lines 3 and 4 display the states for Filter 2.

#### 3.3.3 Parameter Mode





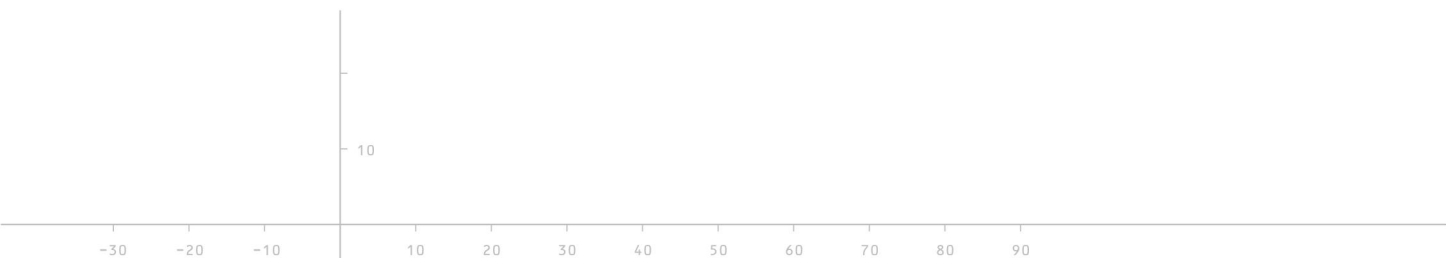



```
Type of Device:
one Filter
```

In Parameter mode, Line 1 displays the parameter menu option and Line 2 the parameter which can be changed.





### 3.4 Function of the Keys

---

	ON – key	This key is used to switch the control unit on.
	OFF – key	This key is used to switch the control unit off.
	Hand – key	This key is used to switch Hand mode on and off.
	Acknowledgement – key	This key is used to acknowledge faults and release the buzzer relay contact again.
	Arrow Up – key	When used in the display, this key is used to scroll upwards in the values displayed. In Parameter mode, this key is used to increase the input value.
	Arrow Down – key	When used in the display, this key is used to scroll downwards in the values displayed. In Parameter mode, this key is used to decrease the input value.
	Function (FKT) – key	In Parameter mode, this key is used to move one level back or to cancel an entry.
	Enter – key	This key is used to switch to Parameter mode or to confirm input.

#### 3.4.1 Key Combinations

 <span style="font-size: 24px; vertical-align: middle;">+</span> 	Change languages	Change the language by pressing the Function and Arrow Up keys simultaneously.
---	------------------	--

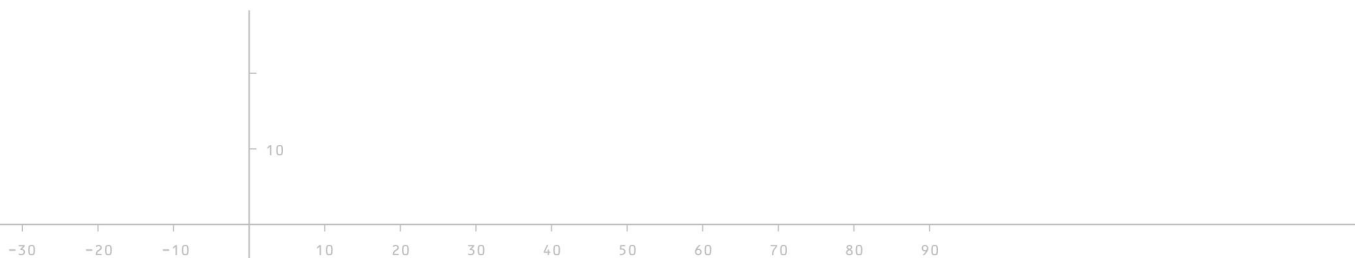



### 3.5 Operating Concept

Parameter configuration is distributed amongst several parameter menus. The respective parameter options are contained in these menus. The parameter options can be accessed as follows by press the Enter key in one of the menus; press the FKT (Function) key to exit from the menu.



**Note: Not all the parameters can be set by means of manual input on the control unit.**

The menus are selected according to the operating concept illustrated below:

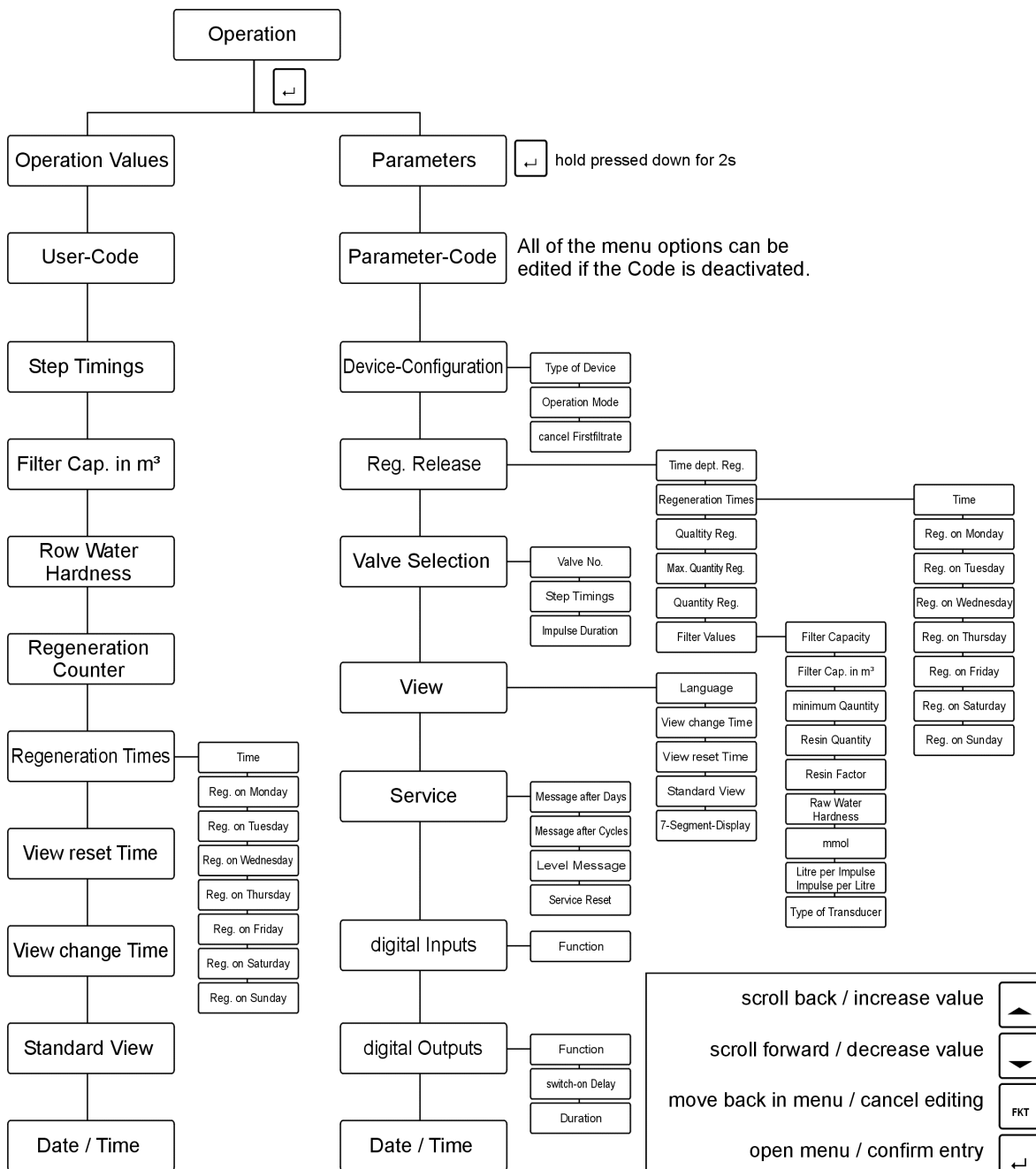

10



### 3.5.1 Editing Parameters

After having selected a parameter option whose value you want to change, it can be edited as follows:

- Press the Enter – key → The last digit in the number flashes
- Press the Arrow keys to change the value
- Press the Enter – key to skip to the next digit

When all the digits have been changed and the last editable digit confirmed with 'Enter', the values are saved. If you exit from editing by pressing the FKT key prior to completing editing of the last digit, the old value remains unchanged.

Use the FKT key at this point to exit from this parameter option and skip to the next one.



**Note:** If no parameter editing was started, press the FKT key to exit from this option and skip directly to the next parameter option without changing the parameter. Not all the parameters can be set by means of manual input on the control unit.

3

4

## 4 Starting Up

After switching the control unit on, certain setting adjustments must be carried out in order to adapt the filter control to your specific filter system.

Some settings can be entered directly on the control unit. Input can be made quickly and easily using the parameterisation – software supplied, which also is available for downloading on our homepage [www.koralewski.de](http://www.koralewski.de) in a current version.

### 4.1 Unit Configuration (Filter Configuration)

Parameter mode is opened by pressing the Enter key for approximately 2 seconds. If the password input lock is active, a prompt appears requesting the 4-digit PIN code. The parameters can only be edited after entering the PIN code (parameter code) correctly. If an password is entered incorrectly or not at all, the operating values and parameters can only be viewed but not changed.

The parameter setting options are described below:

#### 4.1.1 One Filter Mode

Type of Device  
**one Filter**

After selecting 'One filter' mode, the FS-201 is operated with just one filter.

#### 4.1.2 Two Filter Mode

Type of Device  
**two Filter**

After selecting 'Two filter' mode, two filters are operated by the FS-201. A further option is available to define whether the two filters should be run in parallel operation or half – duplex transmission.

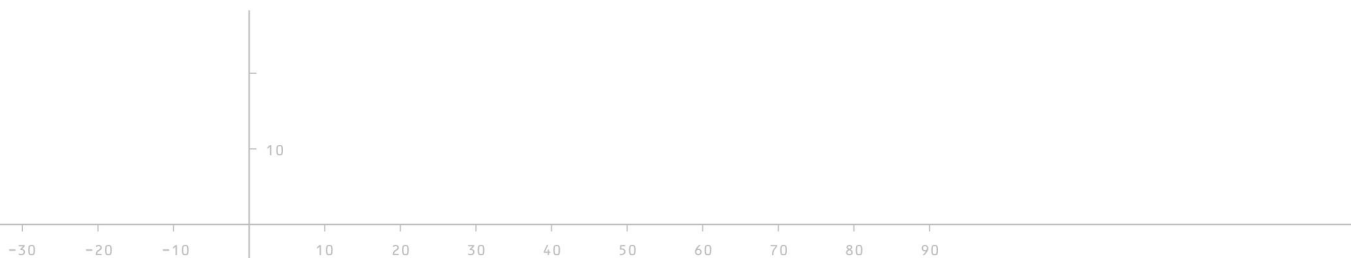



### 4.1.3 Two Filter Mode with Half – Duplex Transmission

Mode of Operation  
**Half-duplex Transm.**

In half-duplex transmission mode, only one filter is in 'OPERATION' at a time, the other filter is in standby. Following a regeneration request, the filter in operation is regenerated and the filter in standby is put into operation.

### 4.1.4 Cancel First Filtrate

cancel Firstfiltrate  
**Yes**

When half - duplex transmission mode has been selected, 'Cancel first filtrate' can also be activated. This function serves to drain off the stale water of a filter in standby before it is put into operation.



**Attention!:** If 'Cancel first filtrate' is activated, a relay output must be assigned the 'Cancel first filtrate' or 'Cancel first filtrate, filter 1 or filter 2' in the relay output configuration (refer to Chapter 9). This relay is then activated when the filter is switched from standby to operation. The respective filter remains in operation until the period of time for 'Cancel first filtrate' has expired. The 'Cancel first filtrate' message appears in the display together with the remaining time.

This relay output can be used to regulate a valve which controls the drainage of water from the filter.

**Note:** The 'Cancel first filtrate' – function cannot be activated in parallel operation!

### 4.1.5 Two Filter Mode in Parallel Operation

Mode of Operation  
**Parallel operation**

When parallel operation is activated, both filters are in 'OPERATION' as long as no regeneration is taking place. Following a regeneration request one of the filters is regenerated, when the next request is received, the other filter is regenerated.

## 4.2 Regeneration Release

The 'Reg. release' menu is used to define the means by which regeneration is triggered and to set the values necessary to do it.

There are various methods to start regeneration. It is also possible to combine methods for starting a regeneration.

### 4.2.1 Regeneration Release according to Time

Time dept. Reg.  
**Yes**

If a filter should be regenerated at a specific time, regardless of the water consumption or an external signal, the regeneration release is set to Time in the FS-201 configuration.

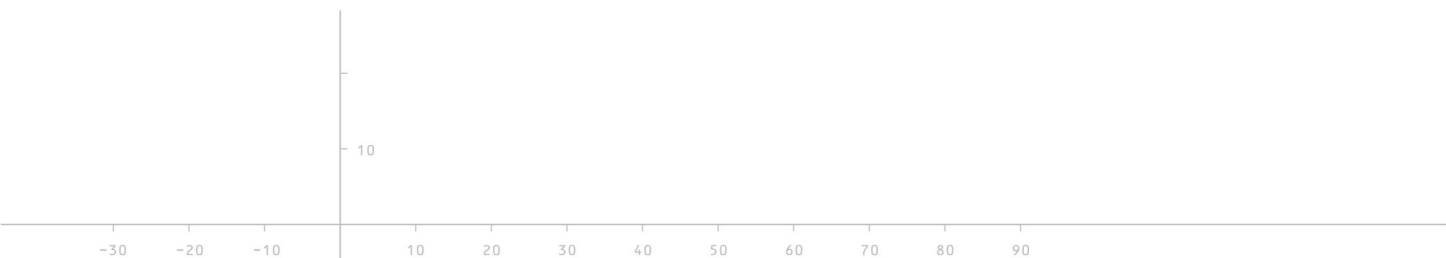



#### 4.2.2 Setting the Regeneration Release Time

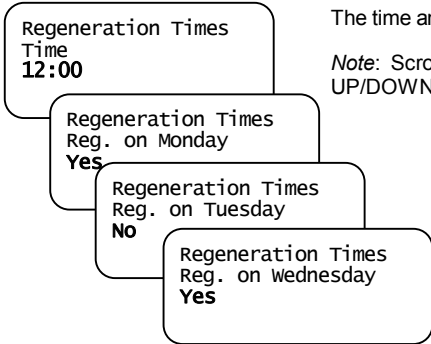

The time and the day or days on which regeneration should occur are entered.

*Note:* Scroll through the different setting points of the sub-menu Regeneration Times with UP/DOWN. (see also 'Filter Capacity' chap. 4.2.1.11).

#### 4.2.3 Regeneration Release according to Quality

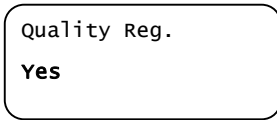

If this method of release is selected, regeneration is triggered by means of an external signal, which e.g. at IN2 (KL 25) is connected. This external signal can come from a water analysis unit (residual hardness tester) or a control center, for example.

#### 4.2.4 Regeneration Release according to Quality (delayed)

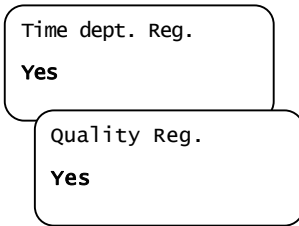

If the filter should be regenerated according to an external signal but also at a specific time, the regeneration release is set to Time and Quality in the FS-201 configuration.

#### 4.2.5 Regeneration Release according to Quantity

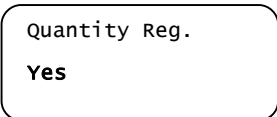

If the filter should only be regenerated according to a specific quantity of water, the regeneration release is set to Quantity in the FS-201 configuration.

**Note:** If a new regeneration amount was entered, the new regeneration amount will be effective after the regeneration of both filter with the old amount.

#### 4.2.6 Regeneration Release according to Quantity (delayed)

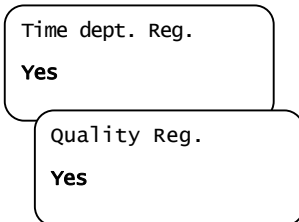

If the filter should be regenerated according to a specific quantity of water but also at a specific time, the regeneration release is set to Quantity and Time in the FS-201 configuration.

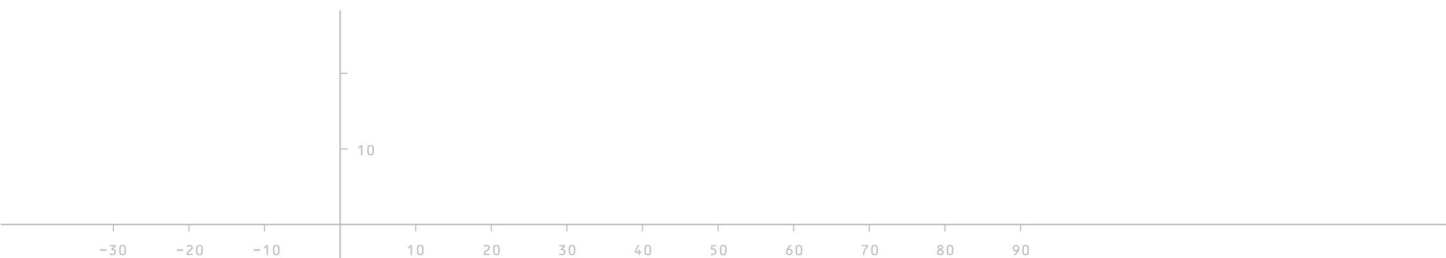



#### 4.2.7 Regeneration Release according to Minimum Quantity

Quality Reg.  
**Yes**

Filter Values  
minimum Quantity  
**10 m<sup>3</sup>**

If the filter should be regenerated according to an external signal but also following a specific minimum quantity, the regeneration release is set to Quality in the FS-201 configuration and a value greater than 0 m<sup>3</sup> must be set for the minimum quantity.

*Note:* The pre-setting for the minimum quantity is done in the submenu 'Filter values' (see chap. 4.2.11).

#### 4.2.8 Regeneration Release according to Minimum Quantity (delayed)

Time dept. Reg.  
**Yes**

Quality Reg.  
**Yes**

Filter Values  
minimum Quantity  
**10 m<sup>3</sup>**

If the filter should be regenerated according to an external signal but also following a specific minimum quantity and at a certain time, the regeneration release is set to Time, Quantity and Quality in the FS-201 configuration.

*Note:* The pre-setting for the minimum quantity is done in the submenu 'Filter values' (see chap. 4.2.11).

#### 4.2.9 Regeneration Release according to Maximum Quantity

Quality Reg.  
**Yes**

Max-Quantity Reg.  
**Yes**

If regeneration of the filter is selected according to an external signal, it is possible to define its release through a maximum quantity. The filter is then regenerated on reaching a maximum quantity even if the external signal has not been received.

Release via the maximum quantity prevents a filter being 'run too long' if, for example, the external signal from a water analysis unit fails.

*Note:* If filter regeneration according to maximum quantity is selected,

- regeneration according to quantity (Chapter 4.2.5 / 4.2.6) is deactivated.
- the value for the maximum quantity is entered in the 'capacity' field.

#### 4.2.10 Regeneration Release according to Maximum Quantity (delayed)

Quality  
**Yes**

Max-Quantity Reg.  
**Yes**

Time dept. Reg.  
**Yes**

If the filter should be regenerated according to an external signal but also following a specific maximum quantity and at a certain time, the regeneration release is set to Time, Maximum Quantity and Quality in the FS-201 configuration.

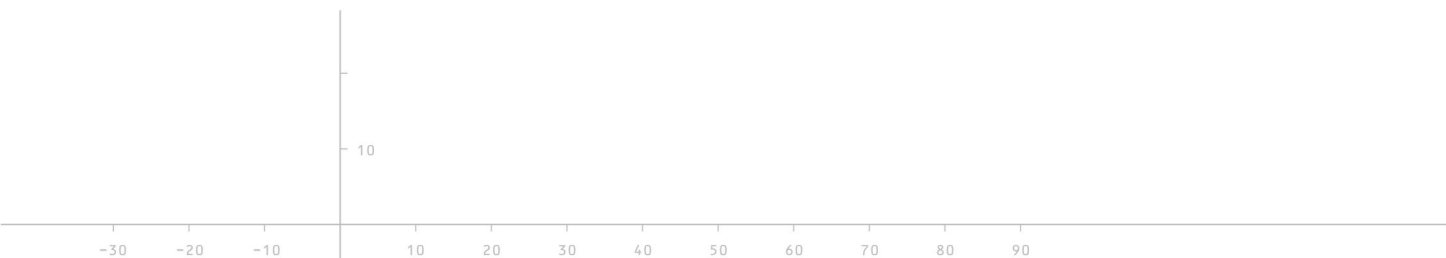



### 4.2.11 Setting the Regeneration Quantities

If **Filter capacity** is selected in the case of a quantity - related release, the regeneration quantity must be entered directly. If raw water hardness is selected as the quantity release factor, in °dH or mmol/l, the specific filter values must be entered and the FS-201 automatically determines the regeneration quantity from them.

*Note:* In the case of releases based purely on time, the set quantity values are irrelevant.

#### 4.2.11.1 Filter Capacity

Filter Values  
Filter capacity  
**Yes**

Filter Values  
Filter Cap. in m3  
**000.0** m3

Filter Values  
minimum Quantity  
**10** m3

The regeneration quantity, according to which a quantity - dependent regeneration should occur, must be entered directly.

If **Filter Capacity** is selected as a value, the quantity (filter capacity) to trigger a regeneration must be entered by the operator. The resin quantity, resin factor and raw water hardness are not taken into account in this case.

*setting range filter capacity (minimum quantity in dependence on this): 0 .... 3200 m³*

*Note:* Scroll through the different setting points of the sub-menu 'Filter Capacity' with UP/DOWN. (see also 'Setting the Regeneration Release Times' chap. 4.2.2).

#### 4.2.11.2 Raw Water Hardness in °dH

Filter Values  
Resin Quantity  
**000** l

Filter Values  
Resin Factor  
**000.0**

Filter Values  
Raw Water Hardness  
**0.00** °dH

Filter Values  
mmol  
**00.000**

The specific filter values are entered (resin quantity, resin factor and raw water hardness in °dH) and the filter control unit automatically calculates the regeneration quantity after which the quantity-dependent regeneration should occur.

*Formula for the automatic calculation of the Filter capacity:*

$\text{Filter capacity [m³]} = (\text{Resin factor [°dH} \cdot \text{m³/L]} \cdot \text{Resin quantity [L]}) [\text{°dH}]$

*setting range Resin Quantity: 0 .... 3200 l, Resin Factor: 0,0 .... 999,9 °dH·m³/L*

*Note:* The resin factor corresponds to the usable volume capacity NVK.

If **Raw Water Hardness in °dH** is selected as a filter value, the values for resin quantity, resin factor and raw water hardness in °dH must also be entered. The quantity (filter capacity) for a regeneration release is then automatically calculated by the FS-201.

*setting range Raw Water Hardness: 0,00 .... 99,99 °dH, mmol: 0,000 .... 17,990*

#### 4.2.11.3 Type of Transducer and Impulse

Filter Values  
Type of Transducer  
**Litre per Impulse**

Filter Values  
Litre per Impulse  
**100**

There are two kinds of transducer available for selection, namely 'Litre per Impulse' and 'Impulse per Litre'. The number of impulses per litres or litres per impulse can be entered in the submenu.

*setting range: 0 .... 9999 Litre per Impulse, resp. 0 .... 9999 Impulse per Litre*

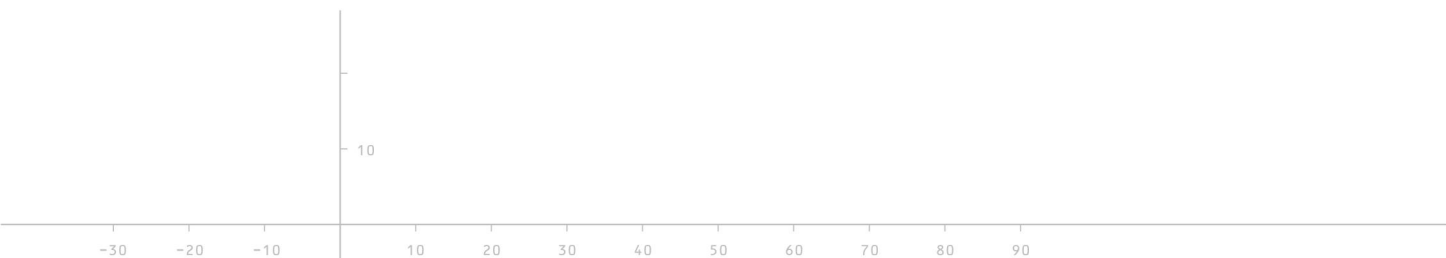



### 4.3 Valve Selection

Valve No.  
PVP-4  
1

These parameter options are used to set the pilot distributor or central control valve used. The following valve types are available for selection:

No.	Manufacturer	Valve type	Name
1	Heyl	pneumatic pilot distributor	PVP-4
2	Heyl	electric pilot distributor	PVE
3	WWS	central control valve	410 / 420 / 541 / 435
4	WWS	central control valve	435
5	WWS	central control valve	415 / 426
6	WWS	central control valve	440 / 441
7	Techap	multiway reversing valve	MUVK 20-40
8	user defined	user defined	
9	user defined	user defined	

#### 4.3.1 User defined Valve

If the applicable valve type is not provided in the selection table, an user defined valve can be configured using the parameterisation – software and choosing number 8 or 9. Detailed settings, as the entries for manufacturer, type of valve, and designation, as well as the definition of the number of steps are available only by using the parameterisation – software. An in this manner configured valve is, as well as the predefined valves, selectable and, with the below described valve settings, configurable on device.

### 4.4 Impulse Duration

Impulse Duration  
5 s

If IMPULSE is selected as the release type, the duration of the impulse must be defined here in seconds. In the case of HALF-DUPLEX, the minimum running time must comply with the longest half - duplex time of the pilot distributor.

setting range: 0 .... 9999 s

### 4.5 Step Timings

Step Timings  
Step Delay 01  
1800 s

After selecting a valve type or creating a user - defined valve, the step timings for the individual regeneration steps can be set. The number of steps is dependent on the valve selected.

setting range: 0 .... 9999 s

Note: Using the parameterisation – software an individual description can be entered for each step of the respective valve.

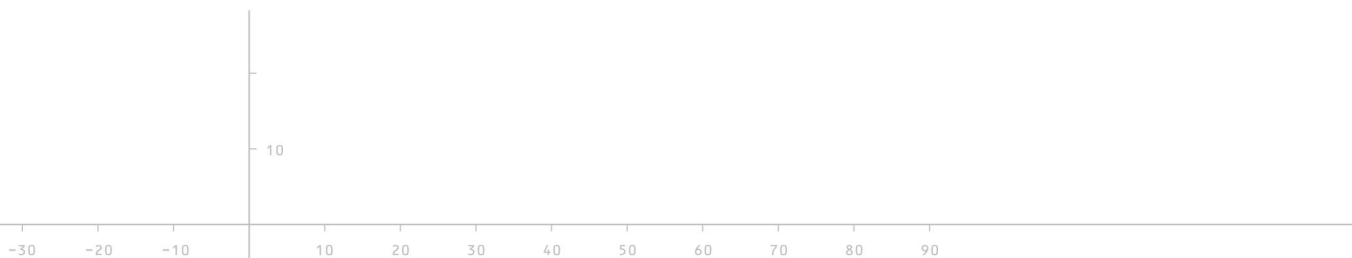



## 5 System and Indicators

This menu is used to define the display format and display values for the 7-segment display view and LC display as well as system settings.

### 5.1 Changing Languages

Language  
2

This menu option is used to switch between the two languages integrated in the filter control unit.

*selection: 1 or 2*

### 5.2 View Change Time

If several display values are possible, e.g. remaining quantity and time-controlled release, this option can be used to define the time interval at which the display view is changed.

*setting range: 0 .... 100 s*

If the time is set to 0 seconds, the view will not automatically be changed and the standard view is displayed continuously.

### 5.3 View Reset Time

The Arrow keys are used to scroll through the individual parameter values in the display view. If a time greater than 0 s is defined for this setting, the system automatically reverts to the standard view after the time defined has elapsed.

*setting range: 0 .... 200 s*

If the time defined is 0 s, the display view selected using the Arrow keys remains until a new value is selected with the Arrow keys or the FS-201 is restarted.

### 5.4 Standard View

During operation of the FS-201 it is possible to scroll through the operating values and regeneration values by using the arrow keys. One of 4 available value - overviews can be selected as 'Standard View'. The display switches back to this 'Standard View' automatically after the view reset time elapsed (if a value other than 0 s is set), after a regeneration is completed or by pushing the 'FKT' - key.

The following selection is available:

Filter 2 operating  
Capacity: 10.0  
Consumption: 0.0  
remaining:

Active filter (0):

Displays the total capacity, consumption and the remaining quantity to the regeneration of the currently active filter.

Filter1 Cap: 9.5 m3  
Consump.: 0.5 m3  
Filter2 Cap: 9.5 m3  
Consump.: 0.5 m3

Both filters (1):

Displays the remaining capacity to regenerate and the current consumption of both filters.

Date / Time  
Time 7:53 ocl 45 s  
Monday  
Date 15.06.2009

Date / Time (2):

Displays the set date, the day of the week and time.

Overview  
Reg.-Cycles: 5 max  
Filter 1: 3  
Filter 2: 6

Regeneration Overview (3):

Displays the number of regenerations until the message 'Check recycle liquid pool' will be displayed and how many regenerations the respective filter has made.



## 5.5 The 7 – Segment Display View

A standard view can be set for the 7-segment display view. The following views are available for selection:

<b>0</b>	Off	The display view is switched off.
<b>1</b>	Remaining	Displays the quantity remaining until the next regeneration.
<b>2</b>	Consumption	Displays the quantity of water which has flowed through since the last regeneration.
<b>3</b>	Time rem.	Displays the time remaining (in hours) until the next regeneration when regeneration release according to time has been selected.
<b>4</b>	Time since reg.	Displays the time which has elapsed since the last regeneration when regeneration release according to time has been selected.
<b>5</b>	Time	Displays the current time.

optionally:

<b>6-11</b>	Conductance	Displays the conductance value, in which case the measuring unit and counter format can also be selected.
-------------	-------------	---



**Note:** If two filters are operated by the FS-201 in half-duplex mode, the value for the filter currently in use is displayed.

5

6

## 6 Service

In the service menu settings for indication of warnings can be done, which especially for the plant manufacturers are important.

*Note:* Activating / deactivating of maintenance messages as well as editing of the message text can only be done by parameterisation – software. The settings of the running times for the service messages also is possible directly on the device.

### 6.1 Service Messages

Message after Days

90

If a value greater than 0 is set here, a service message appears after lapse of the set number of days.

*setting range:* 0 .... 9999

If the value 0 is set here, the Message After Days function is not active.

Message after Cycles

15

If a value greater than 0 is set here, a service message appears after the set number of regeneration cycles.

*setting range:* 0 .... 9999

If the value 0 is set here, the Message After Cycles function is not active.





## 6.2 Regenerant Monitoring

---

Level Message  
3

If a value greater than 0 is set here, the 'Refill recycle liquid' fault message appears after the set number of regeneration cycles. If the value 0 is set here, the fault message is deactivated.

Press and hold the Acknowledgement key to reset the counter for recycle liquid monitoring.

## 6.3 Service Reset

---

Service Reset  
Reset

The service messages after days and cycles are reset.

## 7 Operating Value Settings

---

The Operating Value menu is provided so that the system operator can change operating values quickly and easily. The most important setting values can be changed here without having to scroll through all the menus.

The following operating values can be edited, depending on the filter configuration:

- Step timings
- Filter capacity / Raw water hardness
- Regeneration release times
- Settings for the display view
- Date / Time

6

7

### 7.1 Regeneration Counter

---

Regeneration Counter  
3

The counter displays the number of regenerations which have been completed since the last RESET.

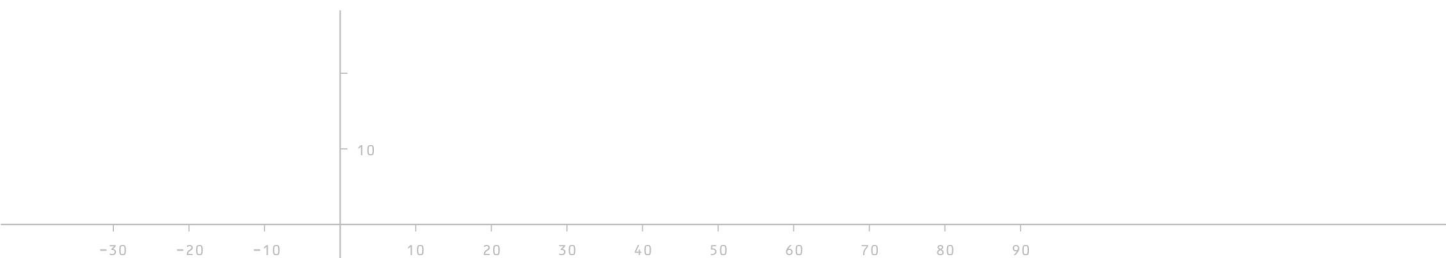



## 8 Inputs

In the case of the inputs, using the parameterisation – software it is possible to select whether the signal should be triggered according to the closed- circuit or open-circuit principle.

**Closed-circuit principle:** If the contact connected to this input is closed, the signal is not evaluated. An evaluation occurs when the contact opens.

**Open-circuit principle:** If the contact connected to this input is open, the signal is not evaluated. An evaluation occurs when the contact closes.

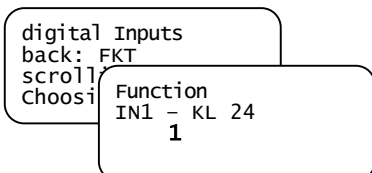

Various functions can be assigned to the inputs.

The following functions are available for selection:

No.	Function	Description
0	No function	No function is assigned to the input.
1	Start regeneration (unconditional)	If this signal is received on the relevant input, a regeneration is triggered immediately regardless of whether other release conditions are fulfilled. This function corresponds to a regeneration release initiated manually.
2	Start regeneration (external signal)	This function causes a regeneration to be started by means of an external signal (e.g. quality measuring device). Other regeneration conditions (e.g. quantity or time) are not taken into account.
3	Inhibit regeneration	If this signal is received on the relevant input, the FS-201 is locked against the regeneration. This serves for locking two FS-201 units.
4	Regenerant deficiency	If an input is assigned this function, the level monitoring device of a recycle liquid tank can be connected to it. When the signal is received, 'Refill recycle liquid' fault message appears.
5	Min. level	This input supplies the min. level signal for the level control <sup>1)</sup> .
6	Max. level	This input supplies the max. level signal for the level control <sup>1)</sup> .
7	Level contact 1	A level contact (e.g. 'too full') can be connected to a tank when the input is configured in this way.  <i>Note:</i> An output must also be assigned the 'Level contact 1' function for this signal (refer to Chapter 9, Function 34).
8	Level contact 2	A level contact (e.g. dry run) can be connected to a tank when the input is configured in this way.  <i>Note:</i> An output must also be assigned the 'Level contact 1' function for this signal (refer to Chapter 9, Function 34).
9	Enable regeneration release	If an input has been assigned this function and the FS-201 is running in two filter operation with half-duplex mode, regeneration of the filter to be regenerated is only started when the regeneration release is issued via this input.
255	Water meter contact (E4)	If a water meter contact is required for the quantity - related release, this function must be assigned to input E4.

<sup>1)</sup> *Note:* The 'Min. level' and 'Max. level' signals must be assigned to an output allocated the 'Level control' function (refer to Chapter 9, Function 33).



## 9 Outputs

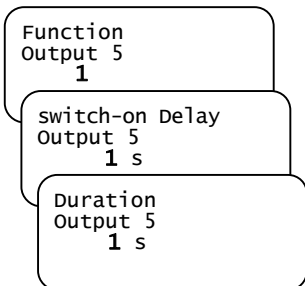

With regard to the outputs, using the parameterisation – software it is possible to select whether the relay should open or close when a signal / event is received (closed-circuit/open-circuit principles).

In addition, the outputs 5 to 8 can be assigned to specific functions, and the delay and running time can be set. The setting range for the delay and running times is **0** up to **9999** seconds.

The following functions are available for the relay outputs:

No.	Function	Description
0	No Function	No function is assigned to this relay.
1	Regeneration step 1	The relay is activated when the filter is in Step 1.
2	Regeneration step 2 <sup>1)</sup>	The relay is activated when the filter is in Step 2.
3	Regeneration step 3 <sup>1)</sup>	The relay is activated when the filter is in Step 3.
4	Regeneration step 4 <sup>1)</sup>	The relay is activated when the filter is in Step 4.
5	Regeneration step 5 <sup>1)</sup>	The relay is activated when the filter is in Step 5.
6	Regeneration step 6 <sup>1)</sup>	The relay is activated when the filter is in Step 6.
7	Regeneration step 7 <sup>1)</sup>	The relay is activated when the filter is in Step 7.
8	Regeneration step 8 <sup>1)</sup>	The relay is activated when the filter is in Step 8.
9	Regeneration step 9 <sup>1)</sup>	The relay is activated when the filter is in Step 9.
10	Regeneration step 10 <sup>1)</sup>	The relay is activated when the filter is in Step 10.
11	Operate FS-201	The relay is activated when the FS-201 is in operation.
12	Automatic operation	The relay is activated when the FS-201 is in Automatic operating mode.
13	Hand operation	The relay is activated when the FS-201 is in Hand operating mode.
14	Operate F1	The relay is activated when Filter 1 is in operation.
15	Operate F2	The relay is activated when Filter 2 is in operation.
16	Filter 1 ready	The relay is activated when Filter 1 is ready to operate.
17	Filter 2 ready	The relay is activated when Filter 2 is ready to operate.

*Note:* This function is only available when the FS-201 is in two filter mode.

<sup>1)</sup>The number of steps is depending on the type of selected valve.

*Note:* The runtime set for the relay for **Functions 1 to 9** is always fully completed in Automatic operation so that it is possible that the corresponding relay remains switched even when the step has ended (runtime greater than the step timing).

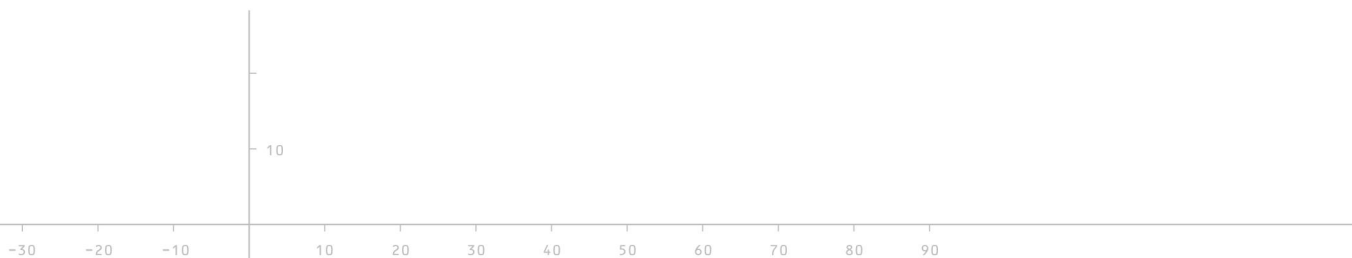



No.	Function	Description
18	Filter 1 regenerating	The relay is activated when Filter 1 is regenerating.
19	Filter 2 regenerating	The relay is activated when Filter 2 is regenerating.  <i>Note:</i> This function is only available when the FS-201 is in two filter mode.
20	Regeneration release unconditional (input En) <sup>2)</sup>	The relay closes when a signal is received at input En <sup>2)</sup> .
21	Regeneration release quality (input En) <sup>2)</sup>	The relay is activated when the regeneration request is received from the signal connected to input En <sup>2)</sup> .
22	Regenerant level (input En) <sup>2)</sup>	The relay is activated when the level message is received from the signal connected to input En <sup>2)</sup> .
23	Regeneration lock (input En) <sup>2)</sup>	The relay is activated when a regeneration is currently in progress. This serves to lock other FS-201 control units.
24	Water meter impulse (input E4)	The relay is activated when a water meter impulse is received. If no further impulse is received within the adjustable delay period, the relay opens again. This relay can be used for the <b>'Water consumption'</b> message.
25	Dosage	The relay is activated together with the E4 (WZ) water meter contact. The relay reacts directly to the water meter impulse if 0s is set as the delay and running time.
26	Alarm	If a relay is configured for alarms, it is activated when a fault message (see chapter 12) occurs. The relay is switched after the delay time has expired and remains active until the ENTER key is pressed. If a further fault message is received while a fault message already acknowledged is still active, the relay is switched gain (new value message).
27	Recycle	The general recycle function activates the relay assigned to it when a filter is in operation but no water consumption occurs. In this case, the 'Switch - on delay' and 'Switch - on time' times run cyclically in an alternating sequence. The switch - on delay is repeatedly restarted through the water meter impulse.
28	Recycle Filter 1	This function is directly assigned to Filter 1. The relay is activated when the filter is ready to operate or is in operation and there is no water consumption. In this case the 'Switch - on delay' and 'Switch - on time' times also run cyclically in an alternating sequence as long as no impulse is received from the water meter.
29	Recycle Filter 2	This function is directly assigned to Filter 2. The relay is activated when the filter is ready to operate or is in operation and there is no water consumption. In this case the 'Switch - on delay' and 'Switch - on time' times also run cyclically in an alternating sequence as long as no impulse is received from the water meter.

<sup>2)</sup> In name 'input En' the 'n' represents the number of the selected input.



No.	Function	Description
30	Cancel first filtrate	This function always activates the relay assigned to it when one of the filters switches from 'ready' to 'in operation'.  <i>Note:</i> The function is only available when the FS-201 operates in two filter mode with half-duplex transmission. 'Cancel first filtrate' must be active for this function (refer to Chapter 4.1.4).
31	Cancel first filtrate Filter 1	'Cancel first filtrate' is directly assigned to Filter 1. The relay is activated when this filter switches from 'ready' to 'in operation'. Filter 2 remains in operation until the time set for draining the water has expired. The function is indicated in the text display and the remaining time is displayed.
32	Cancel first filtrate Filter 2	'Cancel first filtrate' is directly assigned to Filter 2. The relay is activated when this filter switches from 'ready' to 'in operation'. Filter 1 remains in operation until the time set for draining the water has expired. The function is indicated in the text display and the remaining time is displayed.
33	Level control	This output provides a level control for level contacts. To do this, two inputs must be assigned as Min. and Max contacts in the input functions.  On dropping below the Min contact, the relay is closed and on exceeding the Max contact is open again (hysteresis).
34	Level contact 1	The relay is activated concurrently with the input configured as 'Level contact 1' in the input function.
35	Level contact 2	The relay is activated concurrently with the input configured as 'Level contact 2' in the input function.
36	Conductance value > Limit value 1	If the FS-201 is equipped for conductance measurements (optional), the output relay configured is activated when the set limit value is exceeded.
37	Conductance value < Limit value 2	If the FS-201 is equipped for conductance measurements (optional), the output relay configured is activated when the conductance value is below set limit.

9

10

## 10 Setting the Time

Date / Time  
 Time 12:43 oC1 12 s  
 Date 15.06.2009  
 Monday

The time and date are set here.

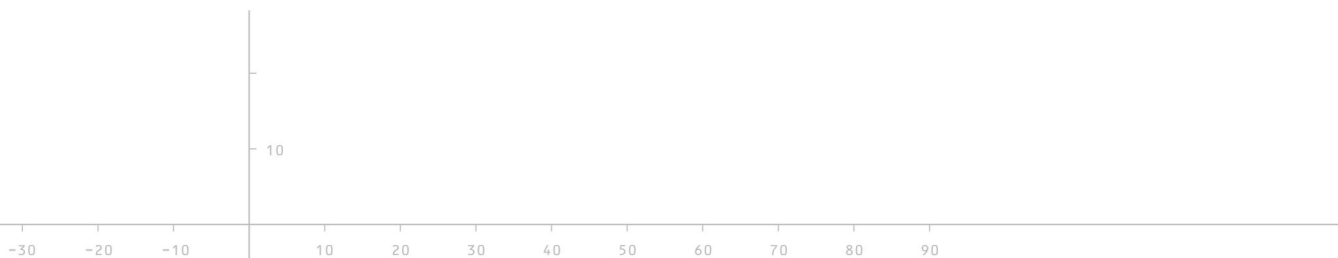



## 11 Manual Operating Options

### 11.1 Changing the Filter in Automatic Mode



If the FS-201 is in Automatic operating mode (yellow LED in the Hand key is OFF) and it is running with two filters in half-duplex mode, a filter can be changed after pressing the two Arrow keys simultaneously for 2 seconds. The filter which is ready in standby is put into operation and the filter previously in operation reverts to standby. The counters of the respective filter are retained.

### 11.2 Hand Operation



Activate Hand operating mode by pressing the Hand key. The yellow LED in the key lights up. If Hand operation is activated while a filter is actually regenerating, the regeneration step currently being performed is not automatically switched to the next step when completed. The ongoing regeneration time is incremented.



*Note:* If the FS-201 is in Hand operating mode, regeneration is no longer started automatically.

### 11.3 Regeneration Release in Hand Operation



If the FS-201 is in Hand operating mode (yellow LED in the Hand key is ON), regeneration of the filter currently in operation can be started by pressing the 'Arrow Down' key for approx. 2 seconds.

### 11.4 Skip to Next Regeneration Step in Hand Operation

When the filter is regenerating, pressing the 'Arrow Down' key for approx 2 seconds causes the system to skip to the next step.

11

12

## 12 Fault Messages

The following fault messages could appear:

\*\*\*\* Fault! \*\*\*\*  
Level  
Recycle Liquid  
low

This fault message appears when a signal, indicating that the level of the recycle liquid has dropped below a set level, is received from the input to which the recycle liquid level monitoring equipment is connected.

\*\*\*\* Fault! \*\*\*\*  
Pool  
Recycle Liquid  
check

This message appears when the set number of regenerations has been reached (refer to Chapter. 7.1). This fault message can be cleared by pressing the 'Acknowledgement' key. If the 'Acknowledgement' key is pressed for 2 seconds, the regeneration counter for this pool message is reset to 0.

\*\*\*\* Fault! \*\*\*\*  
Service Interval  
Maintenance  
ring up Service

This message appears when the regeneration counter has reached the configured number of regenerations or the service interval is reached (Service after xxx days). This fault message can only be acknowledged when a reset is executed under 'Parameter/Service/Service Reset'.

If a fault occurs, the red LED in the Acknowledgement key flashes. After pressing the Acknowledgement key, the red LED lights up continuously. Each time a new alarm is received, the LED starts to flash again. The LED goes out when the cause of the fault is cleared.

10

## 13 Application and Configuration Examples

### 13.1 Operation when Interconnected via a Data Bus (in Preparation)

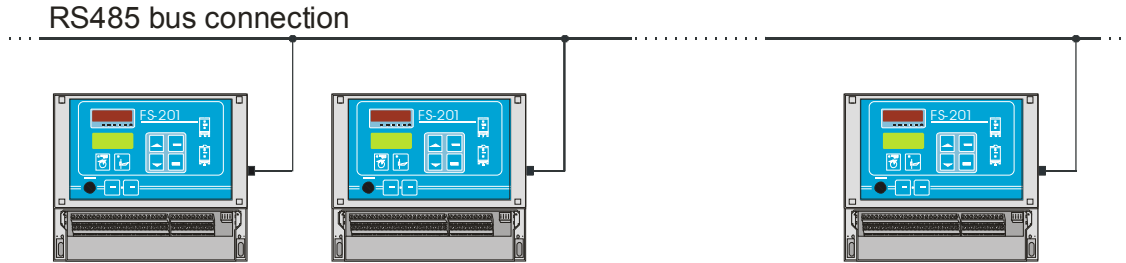

### 13.2 Connection of Two FS-201 in Interconnected Operation

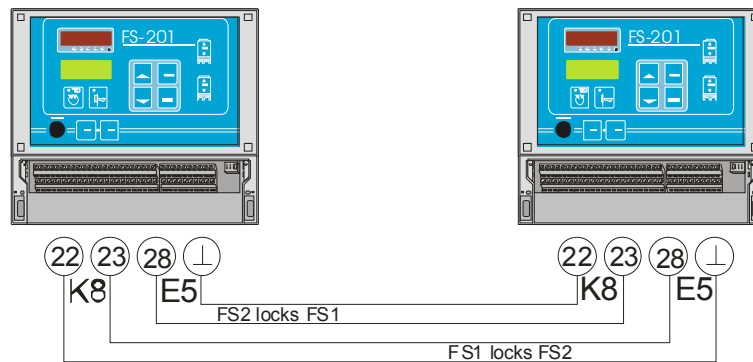

### 13.3 Connection of Several FS-201s in Interconnected Operation

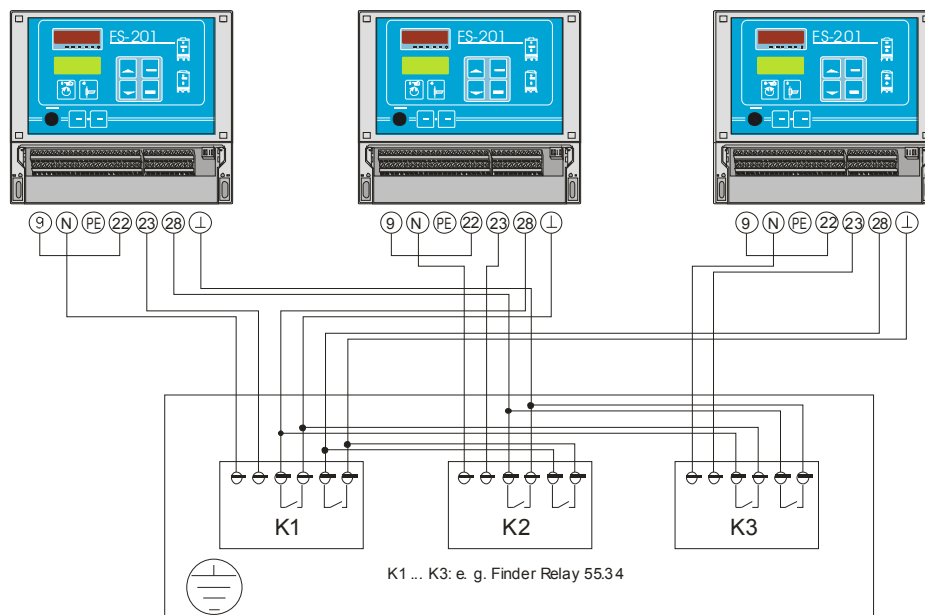

### 13.4 Capacity Setting in Parallel Operation

If two filters are operated with the FS-201 in parallel operating mode, half the total system capacity must be entered when defining the capacity

This is clarified by the figure below:

Status 1:	Status 2:
-----------	-----------

Both filters have a full capacity.  
Start up status

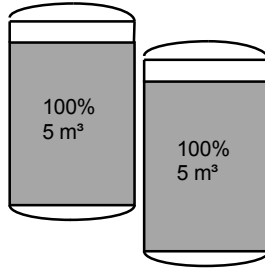

Regeneration quantity reached.  
Regeneration of Filter 1

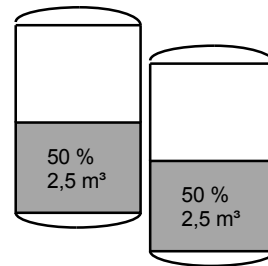

Status 3:	Status 4:
-----------	-----------

Filter 1 has full capacity again.  
End of regeneration of Filter 1

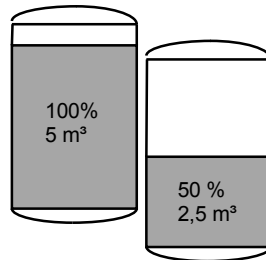

Regeneration quantity reached.  
Regeneration of Filter 2

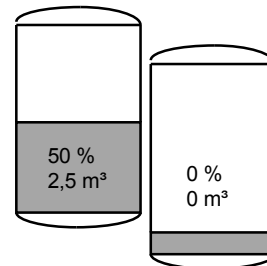

Status 5:
-----------

Filter 2 has full capacity again.  
End of regeneration of Filter 2

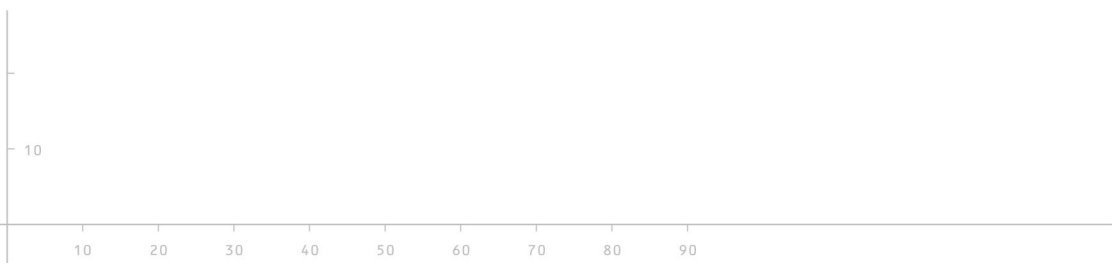
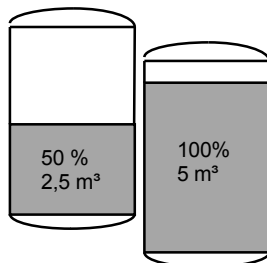



## 14 Technical Data

**Only properly trained personnel may be deployed for assembly and starting up  
Connection in compliance with VDE 0160**

<b>Operating voltage</b>	230 V / 50 Hz (-10 / + 6 %)
<b>Fuse for 230 V version</b>	4 A T (alternatively 4 A mT)
<b>Power consumption</b>	approx. 8 VA (without external consumer)
<b>Option 24 V Version</b>	24 V AC, max. valve supply 20 VA, fuse 1 A T
<b>Data retention following power failure</b>	Time: Min. 72 hours  Configuration, operation and parameter data permanently stored in the internal Flash memory
<b>Outputs</b>	two phase-assigned change-over contacts ( 230 V AC)  two phase-assigned normally open switches ( 230 V AC)  jointly fused by 4 A T  three neutral change-over contacts  one neutral normally open switch  Relay contact: 230 V AC / 8A (AgNi)
<b>Inputs</b>	six inputs via optocoupler  Contact load 10 V DC, approx. 8 mA
<b>Operating temperature</b>	-20 ... +55 °C
<b>Housing</b>	DIN plastic housing for wall installation IP 54 Dimensions: W / H / D : 212 x 184 x 94 mm

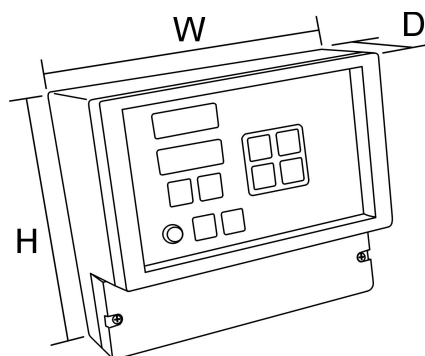

### 14.1 Ordering Information

Filter Control FS-201	Part number
230 V – version:	<b>E1330</b>
230 V / 24 V – version:	<b>E1332</b>
<i>alternatively:</i>	
Filter Control FS-21	Part number
230 V – version:	<b>E1339</b>
230 V / 24 V – version:	<b>E1340</b>

**Note:** In difference to the FS-201 the FS-21 has three conditional functions, four digital inputs / six relay outputs and no 7-segment display view.





# 15 Connection Example

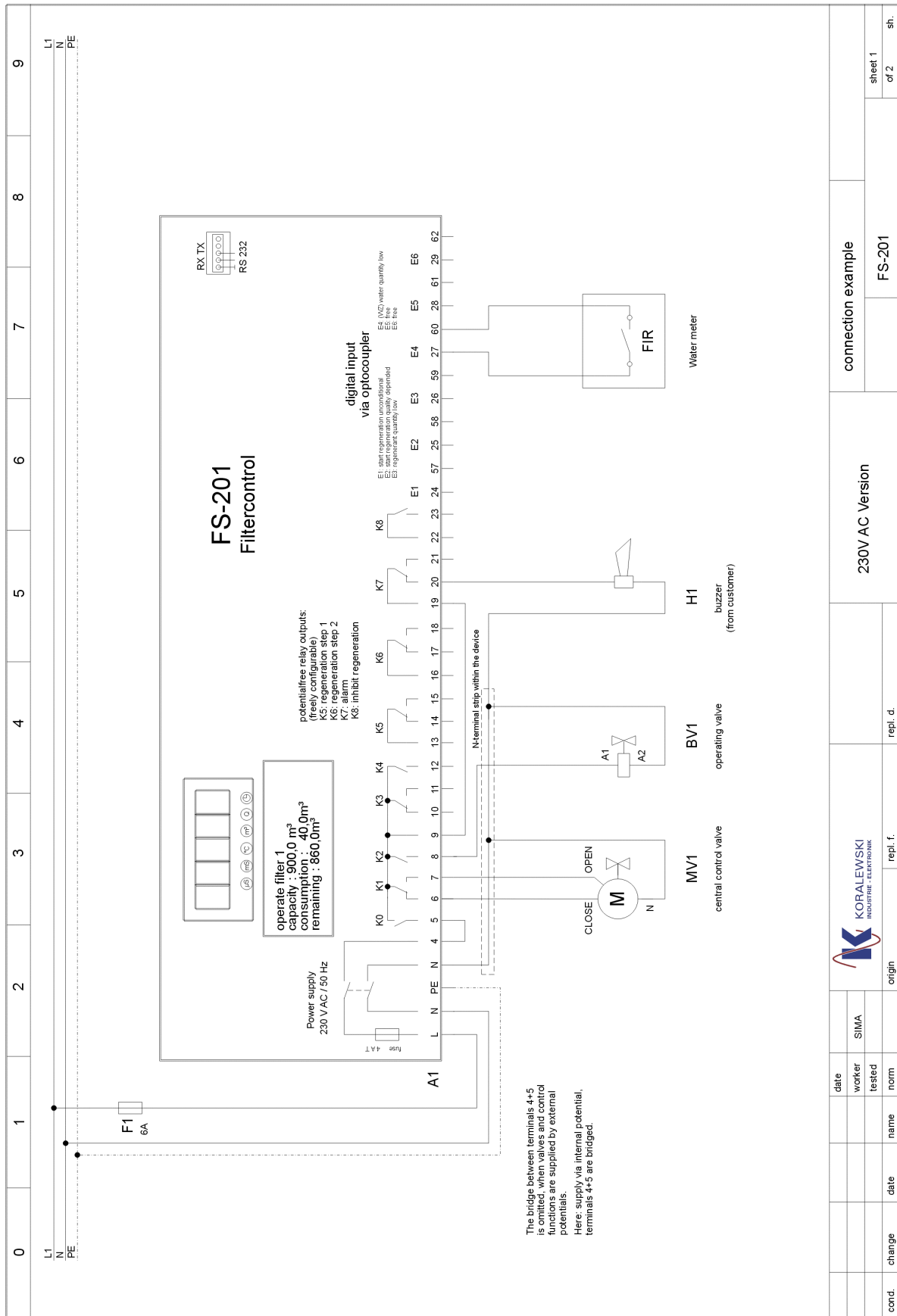

cond.	change	date	name	date	norm	tested	worker	date	repl. f.	repl. d.	230V AC Version	connection example	FS-201	sheet 1 of 2	sh.
-------	--------	------	------	------	------	--------	--------	------	----------	----------	-----------------	--------------------	--------	--------------	-----

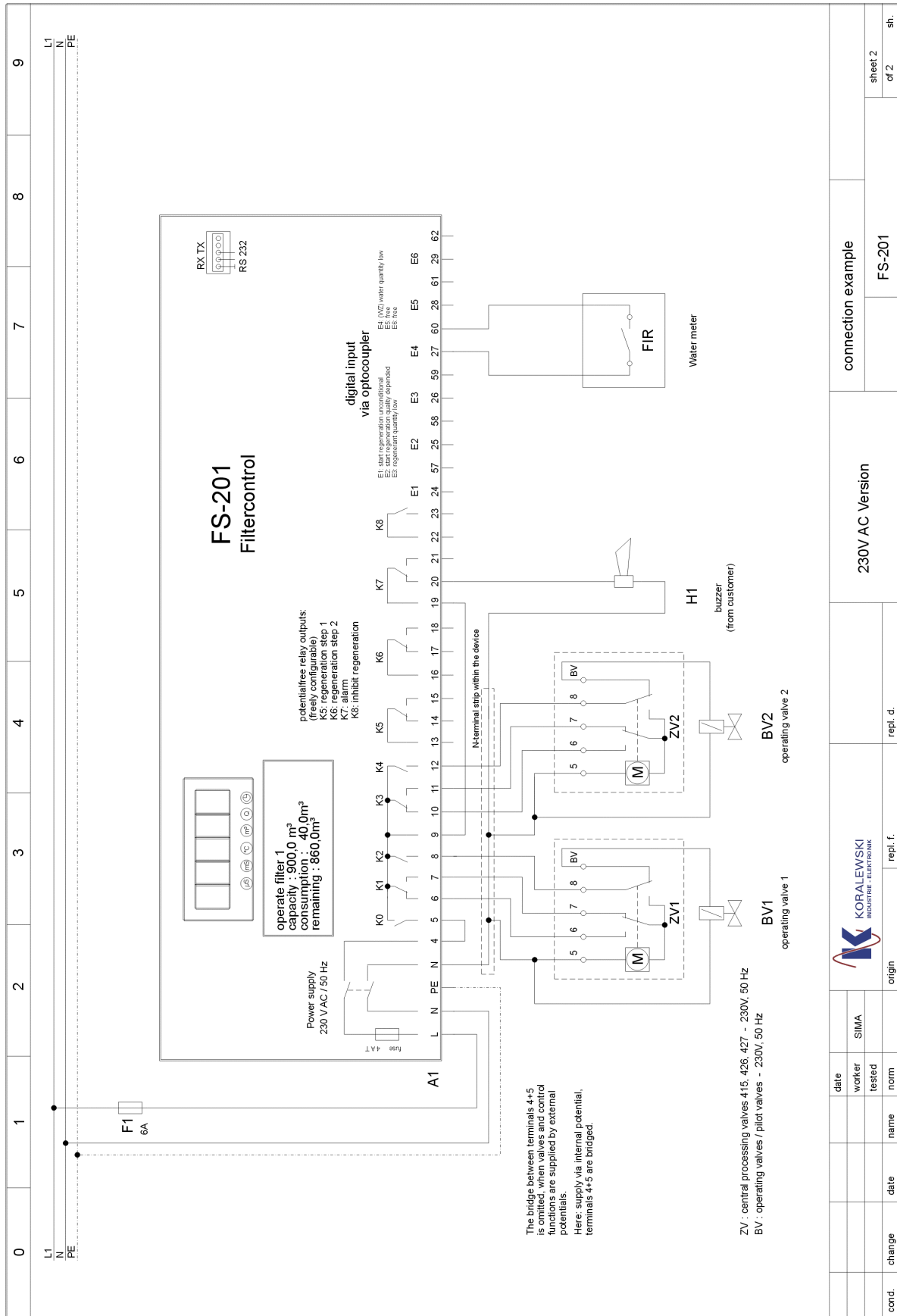

KORALEWSKI  
INDUSTRIE - ELEKTRONIK

date	worker	SIMA	norm	origin	repl. f.	repl. d.

230V AC Version

connection example

FS-201

sheet 2

of 2

sh.



## 16 Default Settings

Consignment: \_\_\_\_\_ Date: \_\_\_\_\_

### Configuration:

- 1. Number of Filters**  1 Filter *or*  2 Filters
- 2. Operating mode**  Parallel- *or*  Half – duplex transmission
- 3. Cancel first filtrate**  Yes *or*  No
- 4. Regeneration** Time  / at **12 : 00** o Clock  
 Weekday:  Mon  Tue  Wed  Thu  Fri  Sat  Sun  
 Maximal quantity /  Quantity /  Quality
- 5. Filter values**  
 Filter capacity **10.0** m<sup>3</sup>  
 Minimum Quantity **10** m<sup>3</sup>  
 Resin Quantity **10** l  
 Resin factor **1.0**  
 Raw water hardness **1.00** °dH  
 mmol **0.178**  
 Impulse per Liter *or*  Liter per Impulse **100**
- 6. Valve type**  PVP-4  PVE  410  420  541  435  
 415  426  440  441  MUVK 20-40
- 7. Program step timings** (No. Regeneration step ..... Seconds)  
 Reg.-step 1 **60** sec.; Reg.-step 2 **60** sec.; Reg.-step 3 **60** sec.;  
 Reg.-step 4 \_\_\_ sec.; Reg.-step 5 \_\_\_ sec.; Reg.-step 6 \_\_\_ sec.;  
 Reg.-step 7 \_\_\_ sec.; Reg.-step 8 \_\_\_ sec.; Reg.-step 9 \_\_\_ sec.;  
 Reg.-step 10 \_\_\_ sec.; Impulse / Running time **90** sec.
- 8. Service** after **180** days / after **60** cycles / level alarm after **5** Reg.

9. Digital Inputs	Input	Function	closed-circ.	<i>or</i>	opened-circ.
	E1	1 Start regen. (unconditional)	<input type="checkbox"/>		<input checked="" type="checkbox"/>
	E2	2 Start regen. (quality dep.)	<input type="checkbox"/>		<input checked="" type="checkbox"/>
	E3	4 Regenerant deficiency	<input type="checkbox"/>		<input checked="" type="checkbox"/>
	E4	255 Water meter	<input type="checkbox"/>		<input checked="" type="checkbox"/>
	E5	0 no function	<input type="checkbox"/>		<input checked="" type="checkbox"/>
	E6	0 no function	<input type="checkbox"/>		<input checked="" type="checkbox"/>

10. Digital outputs	Output	Function	Sw.-on delay	S.-off delay	Close- / Open-circ
	A5	Reg. – step 1	0 sec.	0 sec.	<input type="checkbox"/> <i>or</i> <input checked="" type="checkbox"/>
	A6	Reg. – step 2	0 sec.	0 sec.	<input type="checkbox"/> <i>or</i> <input checked="" type="checkbox"/>
	A7	Alarm	0 sec.	0 sec.	<input type="checkbox"/> <i>or</i> <input checked="" type="checkbox"/>
	A8	Inhibit regeneration	0 sec.	0 sec.	<input type="checkbox"/> <i>or</i> <input checked="" type="checkbox"/>

10



## 17 Form for Configuration and Parameter Settings

Consignment: \_\_\_\_\_ Date: \_\_\_\_\_

### Configuration:

- 1. Number of Filters**  1 Filter *or*  2 Filters
- 2. Operating mode**  Parallel- *or*  Half – duplex transmission
- 3. Cancel first filtrate**  Yes *or*  No
- 4. Regeneration**  
 Time  / at \_\_\_ : \_\_\_ o Clock  
 Weekday:  Mon  Tue  Wed  Thu  Fri  Sat  Sun  
 Maximal quantity /  Quantity /  Quality
- 5. Filter values**  
 Filter capacity \_\_\_\_\_ . \_\_\_\_\_ m<sup>3</sup>  
 Minimum Quantity \_\_\_\_\_ m<sup>3</sup>  
 Resin Quantity \_\_\_\_\_ l  
 Resin factor \_\_\_\_\_ . \_\_\_\_\_  
 Raw water hardness \_\_\_\_\_ . \_\_\_\_\_ °dH  
 mmol \_\_\_\_\_ . \_\_\_\_\_  
 Impulse per Liter *or*  Liter per Impulse \_\_\_\_\_
- 6. Valve type**  
 PVP-4  PVE  410  420  541  435  
 415  426  440  441  MUVK 20-40
- 7. Program step timings** (No. Regeneration step ..... Seconds  
 Reg.-step 1 \_\_\_ sec.; Reg.-step 2 \_\_\_ sec.; Reg.-step 3 \_\_\_ sec.;  
 Reg.-step 4 \_\_\_ sec.; Reg.-step 5 \_\_\_ sec.; Reg.-step 6 \_\_\_ sec.;  
 Reg.-step 7 \_\_\_ sec.; Reg.-step 8 \_\_\_ sec.; Reg.-step 9 \_\_\_ sec.;  
 Reg.-step 10 \_\_\_ sec.; Impulse / Running time \_\_\_ sec.
- 8. Service** after \_\_\_ days / after \_\_\_ cycles / level alarm after \_\_\_ Reg.

9. Digital Inputs	Input	Function	closed-circ. <i>or</i>	opened-circ.
	E1	_____	<input type="checkbox"/>	<input type="checkbox"/>
	E2	_____	<input type="checkbox"/>	<input type="checkbox"/>
	E3	_____	<input type="checkbox"/>	<input type="checkbox"/>
	E4	_____	<input type="checkbox"/>	<input type="checkbox"/>
	E5	_____	<input type="checkbox"/>	<input type="checkbox"/>
	E6	_____	<input type="checkbox"/>	<input type="checkbox"/>

10. Digital Outputs	Output	Function	Sw.-on delay	S.-off delay	Close- / Open-circ
	A5	_____	_____ sec.	_____ sec.	<input type="checkbox"/> <i>or</i> <input type="checkbox"/>
	A6	_____	_____ sec.	_____ sec.	<input type="checkbox"/> <i>or</i> <input type="checkbox"/>
	A7	_____	_____ sec.	_____ sec.	<input type="checkbox"/> <i>or</i> <input type="checkbox"/>
	A8	_____	_____ sec.	_____ sec.	<input type="checkbox"/> <i>or</i> <input type="checkbox"/>